

## LM195/LM395 Ultra Reliable Power Transistors

### General Description

The LM195/LM395 are fast, monolithic power transistors with complete overload protection. These devices, which act as high gain power transistors, have included on the chip, current limiting, power limiting, and thermal overload protection making them virtually impossible to destroy from any type of overload. In the standard TO-3 transistor power package, the LM195 will deliver load currents in excess of 1.0A and can switch 40V in 500 ns.

The inclusion of thermal limiting, a feature not easily available in discrete designs, provides virtually absolute protection against overload. Excessive power dissipation or inadequate heat sinking causes the thermal limiting circuitry to turn off the device preventing excessive heating.

The LM195 offers a significant increase in reliability as well as simplifying power circuitry. In some applications, where protection is unusually difficult, such as switching regulators, lamp or solenoid drivers where normal power dissipation is low, the LM195 is especially advantageous.

The LM195 is easy to use and only a few precautions need be observed. Excessive collector to emitter voltage can destroy the LM195 as with any power transistor. When the device is used as an emitter follower with low source imped-

ance, it is necessary to insert a 5.0k resistor in series with the base lead to prevent possible emitter follower oscillations. Although the device is usually stable as an emitter follower, the resistor eliminates the possibility of trouble without degrading performance. Finally, since it has good high frequency response, supply bypassing is recommended.

For low-power applications (under 100 mA), refer to the LP395 Ultra Reliable Power Transistor.

The LM195/LM395 are available in standard TO-3 power packages and solid Kovar TO-5. The LM195 is rated for operation from  $-55^{\circ}\text{C}$  to  $+150^{\circ}\text{C}$  and the LM395 from  $0^{\circ}\text{C}$  to  $+125^{\circ}\text{C}$ .

### Features

- Internal thermal limiting
- Greater than 1.0A output current
- 3.0  $\mu\text{A}$  typical base current
- 500 ns switching time
- 2.0V saturation
- Base can be driven up to 40V without damage
- Directly interfaces with CMOS or TTL
- 100% electrical burn-in

### Simplified Circuit

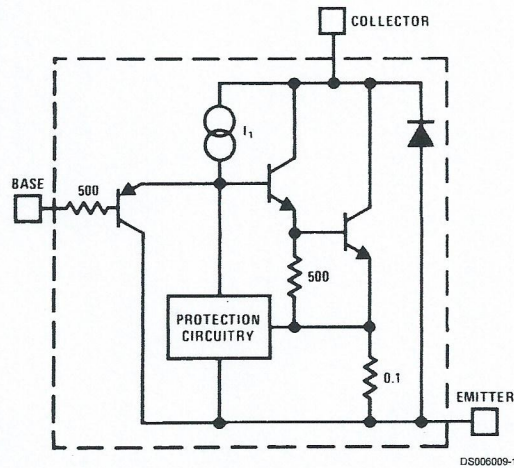

## Connection Diagrams

TO-3 Metal Can Package

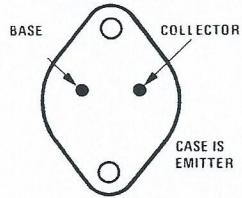

DS006009-2

**Bottom View**  
**Order Number LM195K/883**  
**See NS Package Number K02A**

TO-220 Plastic Package

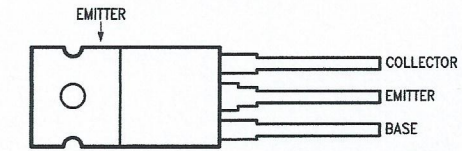

DS006009-3

**Top View**  
**Order Number LM395T**  
**See NS Package Number T03B**

TO-5 Metal Can Package

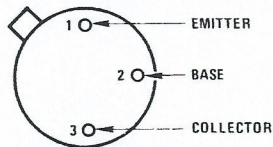

CASE IS EMITTER

DS006009-4

**Bottom View**  
**Order Number LM195H/883**  
**See NS Package Number H03B**

### Absolute Maximum Ratings (Note 1)

If Military/Aerospace specified devices are required, please contact the National Semiconductor Sales Office/ Distributors for availability and specifications.

Collector to Emitter Voltage	
LM195	42V
LM395	36V
Collector to Base Voltage	
LM195	42V
LM395	36V
Base to Emitter Voltage (Forward)	
LM195	42V
LM395	36V

Base to Emitter Voltage (Reverse)	20V
Collector Current	Internally Limited
Power Dissipation	Internally Limited
Operating Temperature Range	
LM195	-55°C to +150°C
LM395	0°C to +125°C
Storage Temperature Range	-65°C to +150°C
Lead Temperature	
(Soldering, 10 sec.)	260°C

### Preconditioning

100% Burn-In In Thermal Limit

### Electrical Characteristics

(Note 2)

Parameter	Conditions	LM195			LM395			Units
		Min	Typ	Max	Min	Typ	Max	
Collector-Emitter Operating Voltage (Note 4)	$I_Q \leq I_C \leq I_{MAX}$			42			36	V
Base to Emitter Breakdown Voltage	$0 \leq V_{CE} \leq V_{CEMAX}$	42			36	60		V
Collector Current								
TO-3, TO-220	$V_{CE} \leq 15V$	1.2	2.2		1.0	2.2		A
TO-5	$V_{CE} \leq 7.0V$	1.2	1.8		1.0	1.8		A
Saturation Voltage	$I_C \leq 1.0A, T_A = 25^\circ C$		1.8	2.0		1.8	2.2	V
Base Current	$0 \leq I_C \leq I_{MAX}$ $0 \leq V_{CE} \leq V_{CEMAX}$		3.0	5.0		3.0	10	$\mu A$
Quiescent Current ( $I_Q$ )	$V_{be} = 0$ $0 \leq V_{CE} \leq V_{CEMAX}$		2.0	5.0		2.0	10	mA
Base to Emitter Voltage	$I_C = 1.0A, T_A = +25^\circ C$		0.9			0.9		V
Switching Time	$V_{CE} = 36V, R_L = 36\Omega,$ $T_A = 25^\circ C$		500			500		ns
Thermal Resistance Junction to Case (Note 3)	TO-3 Package (K)		2.3	3.0		2.3	3.0	$^\circ C/W$
	TO-5 Package (H)		12	15		12	15	$^\circ C/W$
	TO-220 Package (T)					4	6	$^\circ C/W$

**Note 1:** "Absolute Maximum Ratings" indicate limits beyond which damage to the device may occur. Operating Ratings indicate conditions for which the device is functional, but do not guarantee specific performance limits.

**Note 2:** Unless otherwise specified, these specifications apply for  $-55^\circ C \leq T_J \leq +150^\circ C$  for the LM195 and  $0^\circ C \leq +125^\circ C$  for the LM395.

**Note 3:** Without a heat sink, the thermal resistance of the TO-5 package is about  $+150^\circ C/W$ , while that of the TO-3 package is  $+35^\circ C/W$ .

**Note 4:** Selected devices with higher breakdown available.

**Note 5:** Refer to RETS195H and RETS195K drawings of military LM195H and LM195K versions for specifications.

## Typical Performance Characteristics (for K and T Packages)

### Collector Characteristics

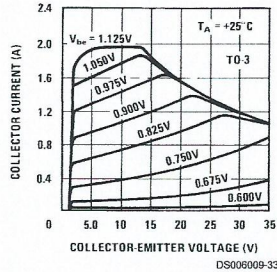

### Short Circuit Current

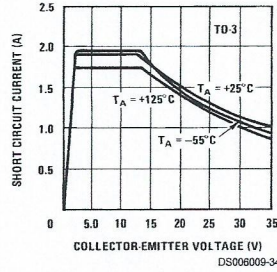

### Bias Current

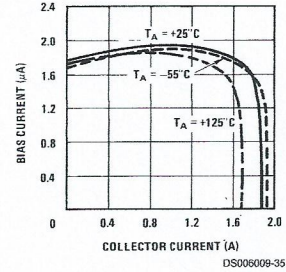

### Quiescent Current

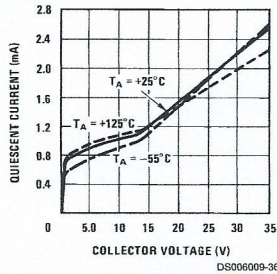

### Base Emitter Voltage

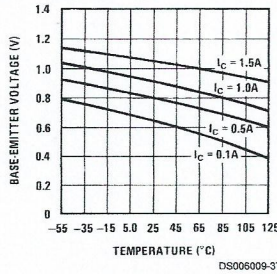

### Base Current

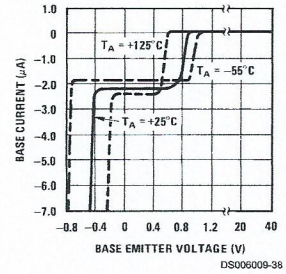

### Saturation Voltage

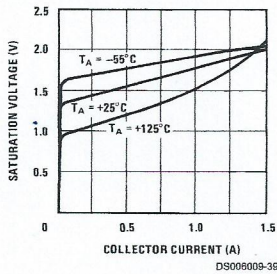

### Response Time

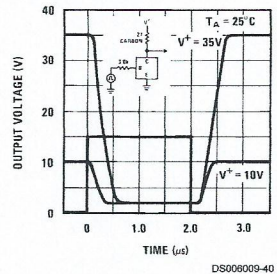

### Response Time

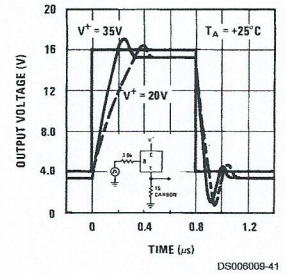

## Typical Performance Characteristics (for K and T Packages) (Continued)

### 10V Transfer Function

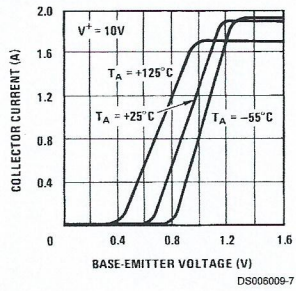

### 36V Transfer Function

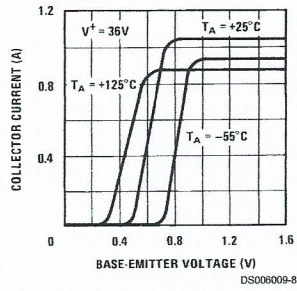

### Transconductance

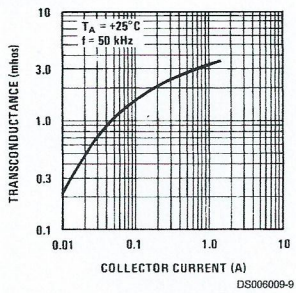

### Small Signal Frequency Response

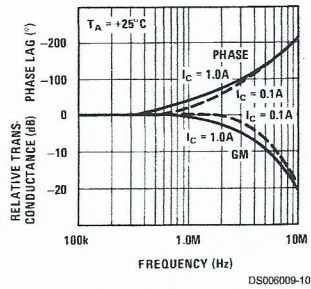

# Schematic Diagram

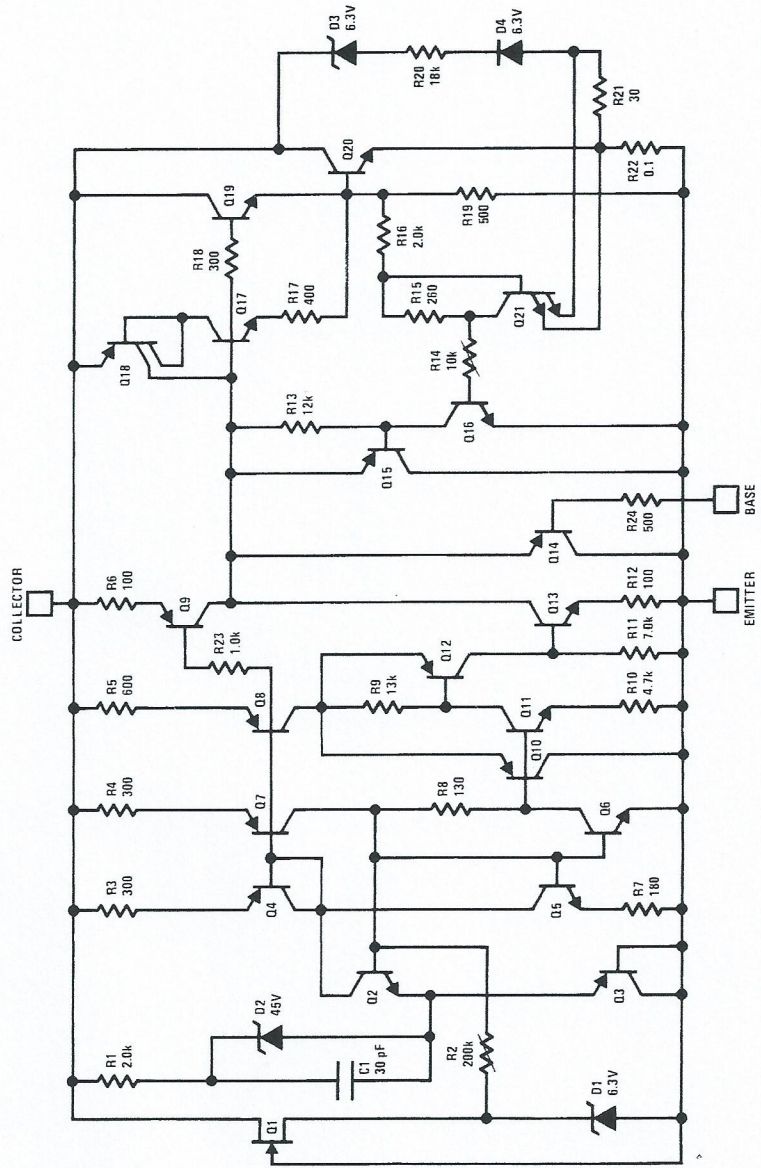

DS90C006-11

## Typical Applications

### 1.0 Amp Voltage Follower

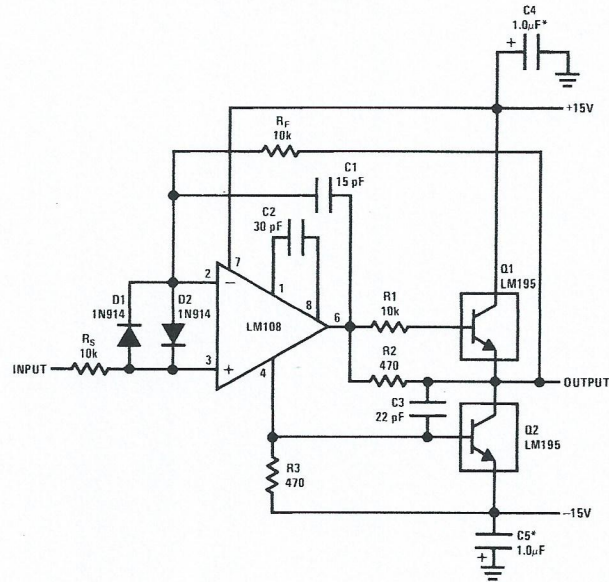

DS006009-12

\*Solid Tantalum

### Power PNP

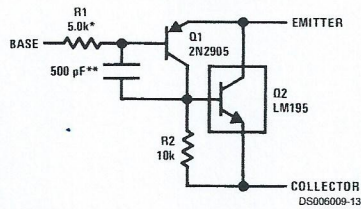

DS006009-13

\*Protects against excessive base drive  
\*\*Needed for stability

### Time Delay

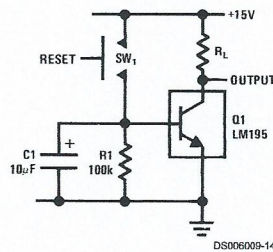

DS006009-14

### 1.0 MHz Oscillator

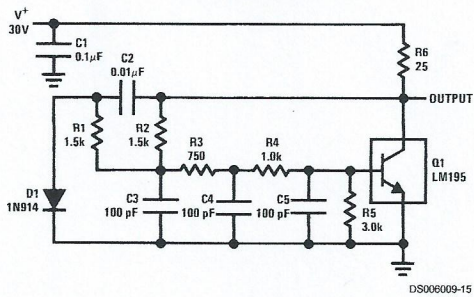

DS006009-15

### 1.0 Amp Lamp Flasher

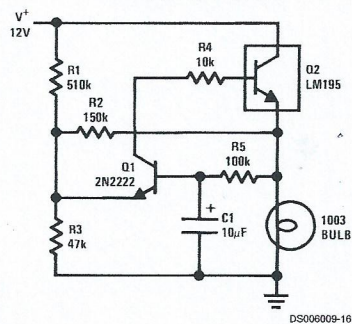

DS006009-16

Typical Applications (Continued)

1.0 Amp Negative Regulator

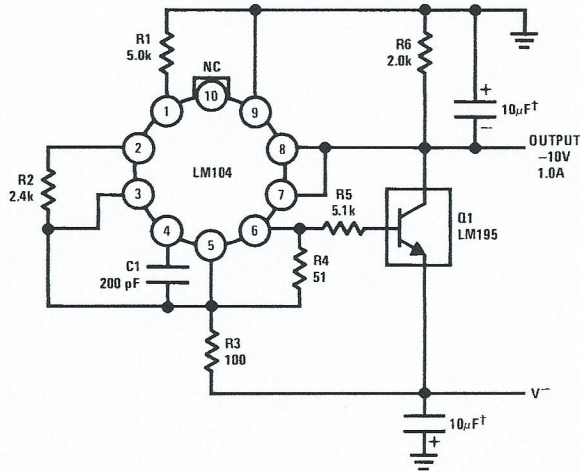

DS006009-17

†Solid Tantalum

1.0 Amp Positive Voltage Regulator

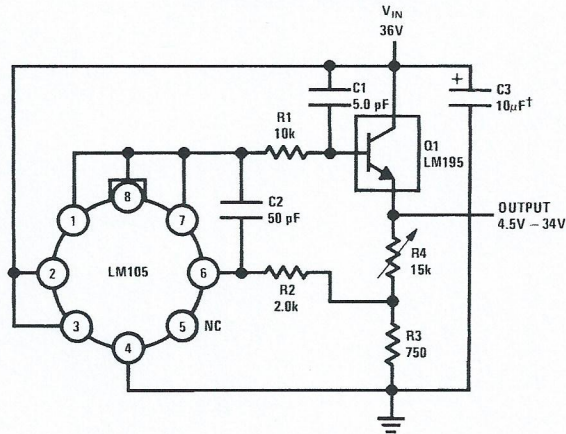

DS006009-18

†Solid Tantalum



## Typical Applications (Continued)

### Fast Optically Isolated Switch

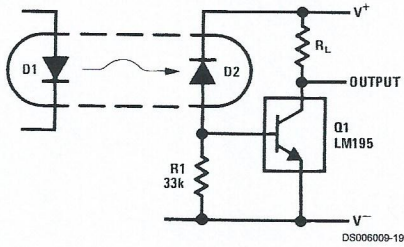

### Optically Isolated Power Transistor

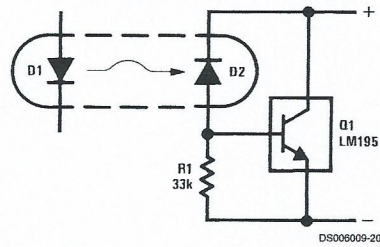

### CMOS or TTL Lamp Interface

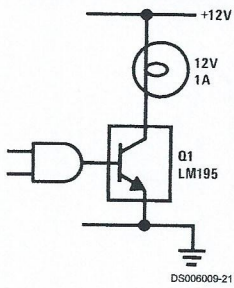

### Two Terminal Current Limiter

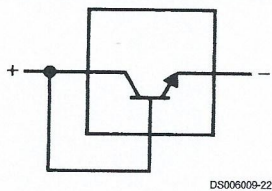

### 40V Switch

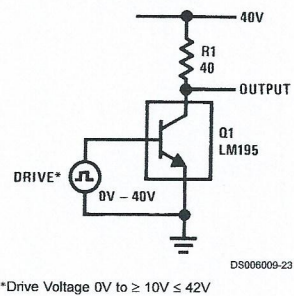

### 6.0V Shunt Regulator with Crowbar

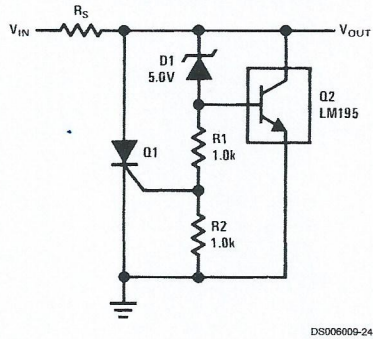

### Two Terminal 100 mA Current Regulator

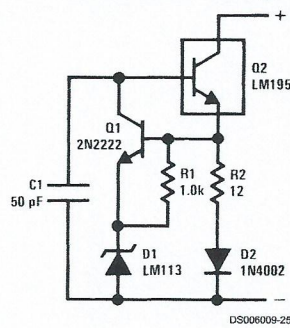

## Typical Applications (Continued)

### Low Level Power Switch

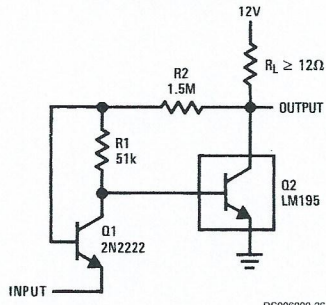

DS006009-26

Turn ON = 350 mV  
Turn OFF = 200 mV

### Power One-Shot

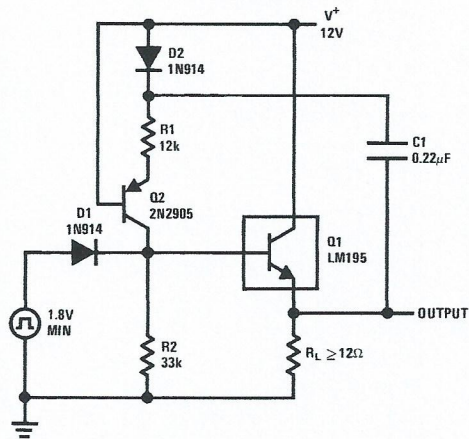

DS006009-27

$T = R1C$   
 $R2 = 3R1$   
 $R2 \leq 82k$

### Emitter Follower

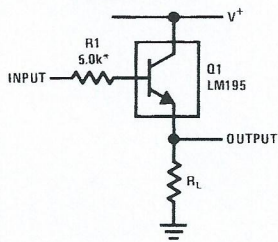

DS006009-28

\*Need for Stability

### High Input Impedance AC Emitter Follower

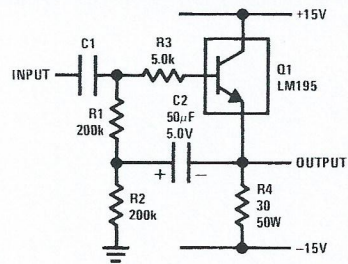

DS006009-29

### Fast Follower

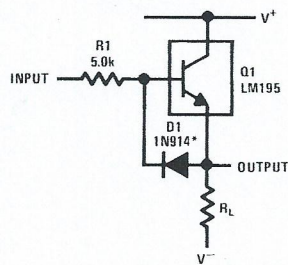

DS006009-30

\*Prevents storage with fast fall time square wave drive

Typical Applications (Continued)

Power Op Amp

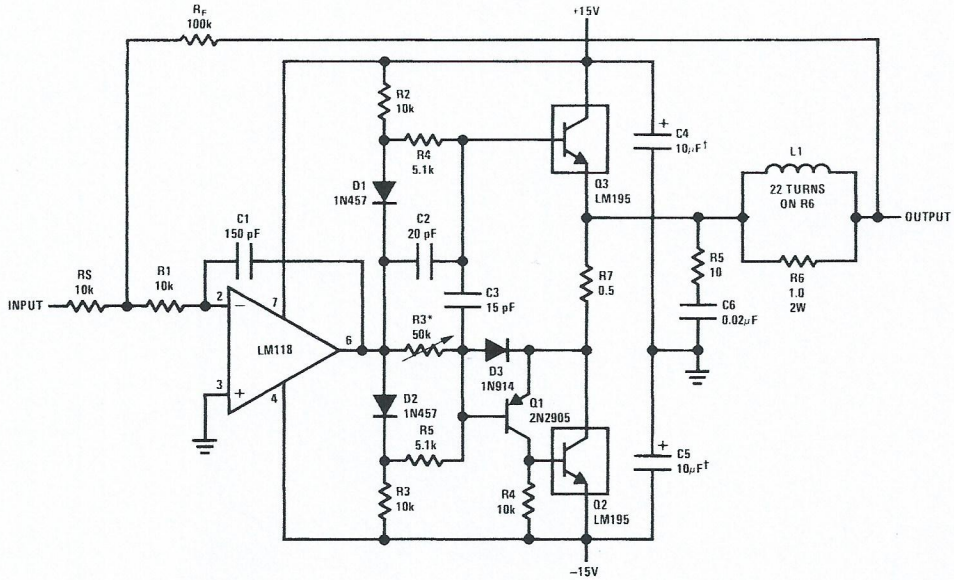

DS006009-31

\*Adjust for 50 mA quiescent current  
†Solid Tantalum

6.0 Amp Variable Output Switching Regulator

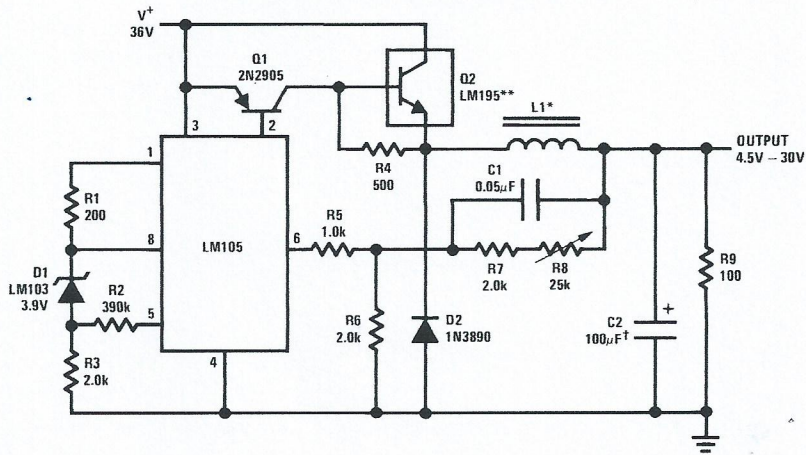

DS006009-32

\*Sixty turns wound on Arnold Type A-083081-2 core.  
\*\*Four devices in parallel  
†Solid tantalum

**Physical Dimensions** inches (millimeters) unless otherwise noted

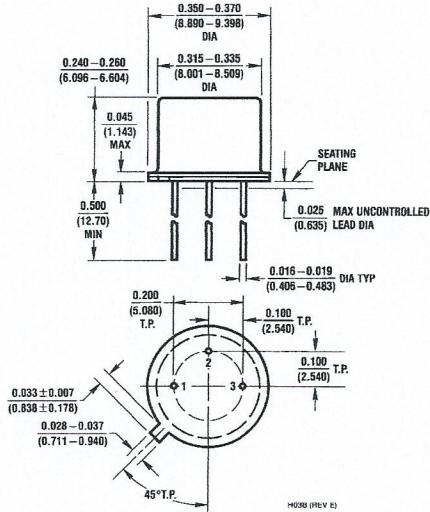

**TO-5 Metal Can Package**  
**Order Number LM195H/883**  
**NS Package Number H03B**

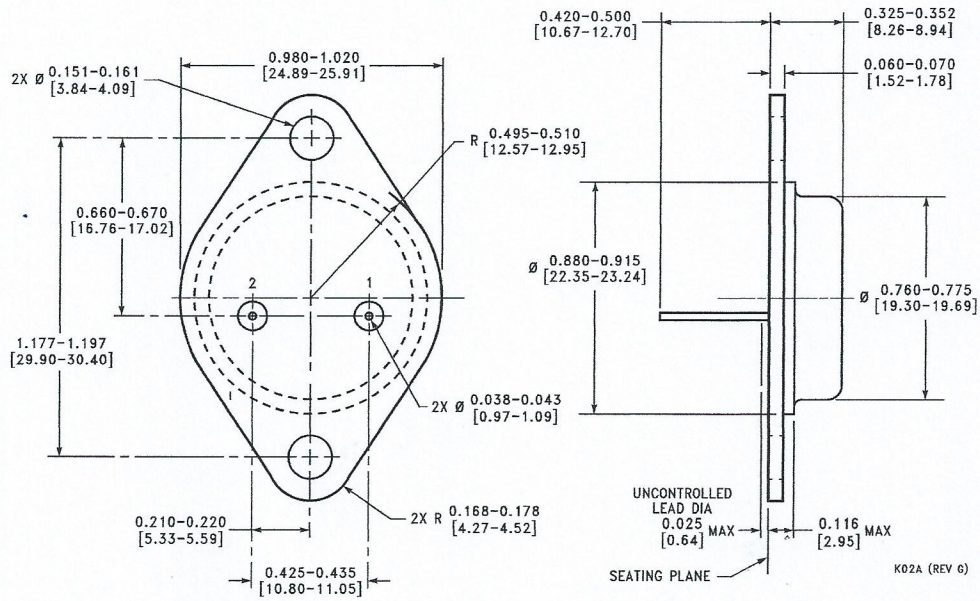

**TO-3 Metal Can Package**  
**Order Number LM195K/883**  
**NS Package Number K02A**

**Physical Dimensions** inches (millimeters) unless otherwise noted (Continued)

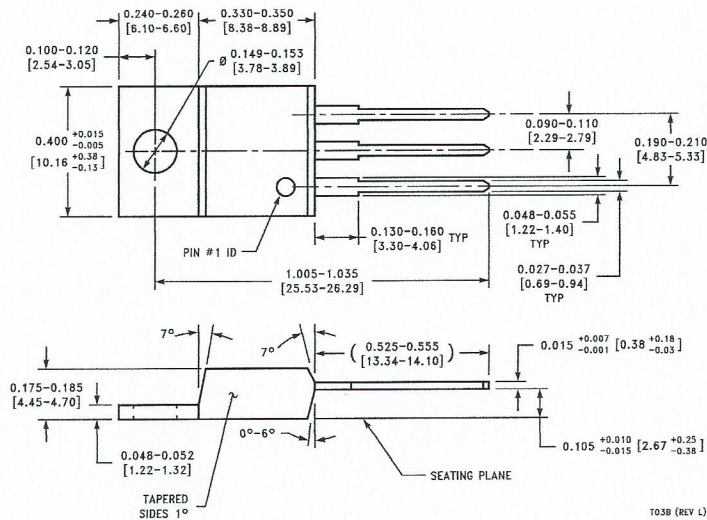

**TO-220 Plastic Package  
Order Number LM395T  
NS Package Number T03B**

**LIFE SUPPORT POLICY**

NATIONAL'S PRODUCTS ARE NOT AUTHORIZED FOR USE AS CRITICAL COMPONENTS IN LIFE SUPPORT DEVICES OR SYSTEMS WITHOUT THE EXPRESS WRITTEN APPROVAL OF THE PRESIDENT AND GENERAL COUNSEL OF NATIONAL SEMICONDUCTOR CORPORATION. As used herein:

1. Life support devices or systems are devices or systems which, (a) are intended for surgical implant into the body, or (b) support or sustain life, and whose failure to perform when properly used in accordance with instructions for use provided in the labeling, can be reasonably expected to result in a significant injury to the user.
2. A critical component is any component of a life support device or system whose failure to perform can be reasonably expected to cause the failure of the life support device or system, or to affect its safety or effectiveness.

**National Semiconductor Corporation**  
Americas  
Tel: 1-800-272-9959  
Fax: 1-800-737-7018  
Email: support@nsc.com  
[www.national.com](http://www.national.com)

**National Semiconductor Europe**  
Fax: +49 (0) 1 80-530 85 86  
Email: europe.support@nsc.com  
Deutsch Tel: +49 (0) 1 80-530 85 85  
English Tel: +49 (0) 1 80-532 78 32  
Français Tel: +49 (0) 1 80-532 93 58  
Italiano Tel: +49 (0) 1 80-534 16 80

**National Semiconductor Asia Pacific Customer Response Group**  
Tel: 65-2544466  
Fax: 65-2504466  
Email: sea.support@nsc.com

**National Semiconductor Japan Ltd.**  
Tel: 81-3-5639-7560  
Fax: 81-3-5639-7507