

## FEATURES

- **Wide Input Voltage Range: 3V to 60V**
- **Low Quiescent Current: 6mA**
- **Internal 5A Switch**  
(2.5A for LT1171, 1.25A for LT1172)
- **Shutdown Mode Draws Only 50µA Supply Current**
- Very Few External Parts Required
- Self-Protected Against Overloads
- Operates in Nearly All Switching Topologies
- Flyback-Regulated Mode Has Fully Floating Outputs
- Comes in Standard 5-Pin Packages
- LT1172 Available in 8-Pin MiniDIP and Surface Mount Packages
- Can Be Externally Synchronized

## APPLICATIONS

- Logic Supply 5V at 10A
- 5V Logic to ±15V Op Amp Supply
- Battery Upconverter
- Power Inverter (+ to -) or (- to +)
- Fully Floating Multiple Outputs

### USER NOTE:

This data sheet is only intended to provide specifications, graphs, and a general functional description of the LT1170/LT1171/LT1172. Application circuits are included to show the capability of the LT1170/LT1171/LT1172. A complete design manual (AN19) should be obtained to assist in developing new designs. This manual contains a comprehensive discussion of both the LT1070 and the external components used with it, as well as complete formulas for calculating the values of these components. The manual can also be used for the LT1170/LT1171/LT1172 by factoring in the higher frequency. A CAD design program called SwitcherCAD® is also available.

## DESCRIPTION

The LT®1170/LT1171/LT1172 are monolithic high power-switching regulators. They can be operated in all standard switching configurations including buck, boost, flyback, forward, inverting and "Cuk." A high current, high efficiency switch is included on the die along with all oscillator, control and protection circuitry. Integration of all functions allows the LT1170/LT1171/LT1172 to be built in a standard 5-pin TO-3 or TO-220 power package as well as the 8-pin packages (LT1172). This makes them extremely easy to use and provides "bust proof" operation similar to that obtained with 3-pin linear regulators.

The LT1170/LT1171/LT1172 operate with supply voltages from 3V to 60V, and draw only 6mA quiescent current. They can deliver load power up to 100W with no external power devices. By utilizing current-mode switching techniques, they provide excellent AC and DC load and line regulation.

The LT1170/LT1171/LT1172 have many unique features not found even on the vastly more difficult to use low power control chips presently available. They use adaptive antisat switch drive to allow very wide ranging load currents with no loss in efficiency. An externally activated shutdown mode reduces total supply current to 50µA typically for standby operation.

LT, LT, LTC, LTM, Linear Technology, the Linear logo and SwitcherCAD are registered trademarks of Linear Technology Corporation. All other trademarks are the property of their respective owners.

## TYPICAL APPLICATION

### Boost Converter (5V to 12V)

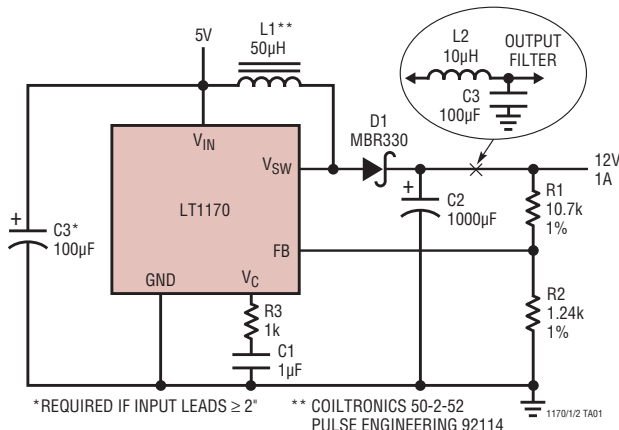

### Maximum Output Power\*

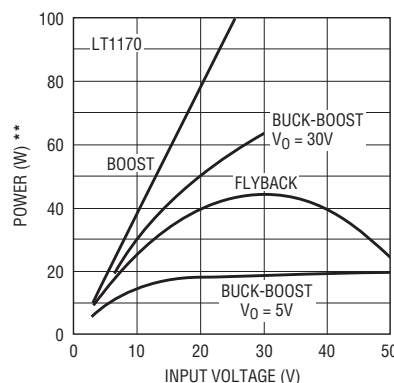

\* ROUGH GUIDE ONLY. BUCK MODE  $P_{OUT} = (5A)(V_{OUT})$ . SPECIAL TOPOLOGIES DELIVER MORE POWER.  
 \*\* DIVIDE VERTICAL POWER SCALE BY TWO FOR LT1171, BY FOUR FOR LT1172.

LT1170/1/2 TA02

# LT1170/LT1171/LT1172

## ABSOLUTE MAXIMUM RATINGS (Note 1)

### Supply Voltage

LT1170/LT1171/LT1172HV (Note 2)	60V
LT1170/LT1171/LT1172 (Note 2)	40V

### Switch Output Voltage

LT1170/LT1171/LT1172HV	75V
LT1170/LT1171/LT1172	65V
LT1172S8	60V

Feedback Pin Voltage (Transient, 1ms) ..... ±15V

Storage Temperature Range ..... -65°C to 150°C

Lead Temperature (Soldering, 10 sec)..... 300°C

### Operating Junction Temperature Range

LT1170M/LT1171M (**OBSOLETE**) ..... -55°C to 150°C

LT1172M ..... -55°C to 125°C

LT1170/LT1171/LT1172HVC,  
LT1170/LT1171/LT1172C (Oper.)..... 0°C to 100°C

LT1170/LT1171/LT1172HVC  
LT1170/LT1171/LT1172C (Sh. Ckt.) ..... 0°C to 125°C

LT1170/LT1171/LT1172HVI,  
LT1170/LT1171/LT1172I (Oper.)..... -40°C to 100°C

LT1170/LT1171/LT1172HVI,  
LT1170/LT1171/LT1172I (Sh. Ckt.)..... -40°C to 125°C

## PIN CONFIGURATION

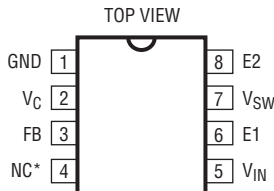
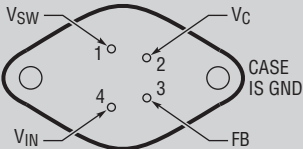
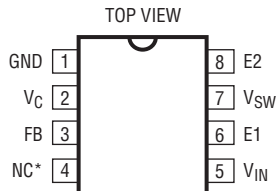
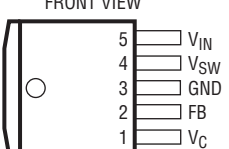
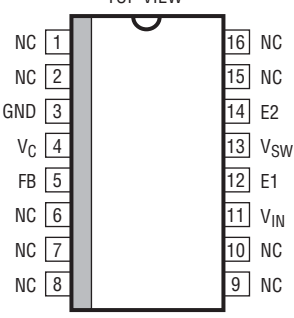
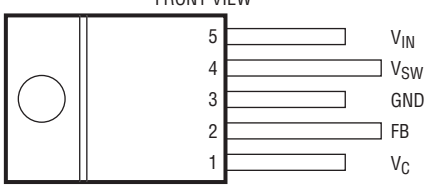
 <p><b>J8 PACKAGE</b> 8-LEAD CERDIP</p> <p><math>T_{JMAX} = 125^{\circ}\text{C}</math>, <math>\theta_{JA} = 100^{\circ}\text{C/W}</math></p> <p>* Do not connect Pin 4 of the LT1172 DIP or SO to external circuitry. This pin may be active in future revisions.</p>	<p><b>BOTTOM VIEW</b></p>  <p><b>K PACKAGE</b> 4-LEAD TO-3 METAL CAN</p> <p>LT1170MK: <math>T_{JMAX} = 150^{\circ}\text{C}</math>, <math>\theta_{JC} = 2^{\circ}\text{C/W}</math>, <math>\theta_{JA} = 35^{\circ}\text{C/W}</math>          LT1170CK: <math>T_{JMAX} = 100^{\circ}\text{C}</math>, <math>\theta_{JC} = 2^{\circ}\text{C/W}</math>, <math>\theta_{JA} = 35^{\circ}\text{C/W}</math>          LT1171MK: <math>T_{JMAX} = 150^{\circ}\text{C}</math>, <math>\theta_{JC} = 4^{\circ}\text{C/W}</math>, <math>\theta_{JA} = 35^{\circ}\text{C/W}</math>          LT1171CK: <math>T_{JMAX} = 100^{\circ}\text{C}</math>, <math>\theta_{JC} = 4^{\circ}\text{C/W}</math>, <math>\theta_{JA} = 35^{\circ}\text{C/W}</math>          LT1172MK: <math>T_{JMAX} = 150^{\circ}\text{C}</math>, <math>\theta_{JC} = 8^{\circ}\text{C/W}</math>, <math>\theta_{JA} = 35^{\circ}\text{C/W}</math>          LT1172CK: <math>T_{JMAX} = 100^{\circ}\text{C}</math>, <math>\theta_{JC} = 8^{\circ}\text{C/W}</math>, <math>\theta_{JA} = 35^{\circ}\text{C/W}</math>          Based on continuous operation.  <math>T_{JMAX} = 125^{\circ}\text{C}</math> for intermittent fault conditions.</p> <p><b>OBSOLETE</b></p>	 <p><b>N8 PACKAGE</b>      <b>S8 PACKAGE</b> 8-LEAD PDIP      8-LEAD PLASTIC SO</p> <p><math>T_{JMAX} = 100^{\circ}\text{C}</math>, <math>\theta_{JA} = 100^{\circ}\text{C/W}</math> (N)  <math>T_{JMAX} = 100^{\circ}\text{C}</math>, <math>\theta_{JA} = 120^{\circ}\text{C/W}</math> to <math>150^{\circ}\text{C/W}</math>          depending on board layout (S)</p> <p>* Do not connect Pin 4 of the LT1172 DIP or SO to external circuitry. This pin may be active in future revisions.</p>
 <p><b>Q PACKAGE</b> 5-LEAD DD</p> <p><math>T_{JMAX} = 100^{\circ}\text{C}</math>, <math>\theta_{JA} = ^{\circ}\text{C/W}</math></p> <p>* <math>\theta</math> will vary from approximately <math>25^{\circ}\text{C/W}</math> with 2.8 sq. in. of 1oz. copper to <math>45^{\circ}\text{C/W}</math> with 0.20 sq. in. of 1oz. copper. Somewhat lower values can be obtained with additional copper layers in multilayer boards.</p>	 <p><b>SW PACKAGE</b> 16-LEAD PLASTIC SO WIDE</p> <p><math>T_{JMAX} = 100^{\circ}\text{C}</math>, <math>\theta_{JA} = 150^{\circ}\text{C/W}</math>          Based on continuous operation.  <math>T_{JMAX} = 125^{\circ}\text{C}</math> for intermittent fault conditions.</p>	 <p><b>T PACKAGE</b> 5-LEAD PLASTIC TO-220</p> <p>LT1170CT/LT1170HVCT: <math>T_{JMAX} = 100^{\circ}\text{C}</math>, <math>\theta_{JC} = 2^{\circ}\text{C/W}</math>, <math>\theta_{JA} = 75^{\circ}\text{C/W}</math>          LT1171CT/LT1171HVCT: <math>T_{JMAX} = 100^{\circ}\text{C}</math>, <math>\theta_{JC} = 4^{\circ}\text{C/W}</math>, <math>\theta_{JA} = 75^{\circ}\text{C/W}</math>          LT1172CT/LT1172HVCT: <math>T_{JMAX} = 100^{\circ}\text{C}</math>, <math>\theta_{JC} = 8^{\circ}\text{C/W}</math>, <math>\theta_{JA} = 75^{\circ}\text{C/W}</math>          Based on continuous operation.  <math>T_{JMAX} = 125^{\circ}\text{C}</math> for intermittent fault conditions.</p>

## ORDER INFORMATION

LEAD FREE FINISH	TAPE AND REEL	PART MARKING	PACKAGE DESCRIPTION	TEMPERATURE RANGE
LT1172MJ8#PBF	LT1172MJ8#TRPBF		8-Lead CERDIP	-55°C to 125°C
LT1172CJ8#PBF <b>(OBSOLETE)</b>	LT1172CJ8#TRPBF		8-Lead CERDIP	0°C to 100°C
LT1170MK#PBF <b>(OBSOLETE)</b>	LT1170MK#TRPBF		4-Lead TO-3 Metal Can	-55°C to 125°C
LT1170CK#PBF <b>(OBSOLETE)</b>	LT1170CK#TRPBF		4-Lead TO-3 Metal Can	0°C to 100°C
LT1171MK#PBF <b>(OBSOLETE)</b>	LT1171MK#TRPBF		4-Lead TO-3 Metal Can	-55°C to 125°C
LT1171CK#PBF <b>(OBSOLETE)</b>	LT1171CK#TRPBF		4-Lead TO-3 Metal Can	0°C to 100°C
LT1172MK#PBF <b>(OBSOLETE)</b>	LT1172MK#TRPBF		4-Lead TO-3 Metal Can	-55°C to 125°C
LT1172CK#PBF <b>(OBSOLETE)</b>	LT1172CK#TRPBF		4-Lead TO-3 Metal Can	0°C to 100°C
LT1172CN8#PBF	LT1172CN8#TRPBF		8-Lead PDIP or 8-Lead Plastic SO	0°C to 100°C
LT1172IN8#PBF	LT1172IN8#TRPBF		8-Lead PDIP or 8-Lead Plastic SO	-40°C to 100°C
LT1172CS8#PBF	LT1172CS8#TRPBF	1172	8-Lead PDIP or 8-Lead Plastic SO	0°C to 100°C
LT1172IS8#PBF	LT1172IS8#TRPBF	1172I	8-Lead PDIP or 8-Lead Plastic SO	-40°C to 100°C
LT1170CQ#PBF	LT1170CQ#TRPBF		5-Lead DD	0°C to 100°C
LT1170IQ#PBF	LT1170IQ#TRPBF		5-Lead DD	-40°C to 100°C
LT1170HVCQ#PBF	LT1170HVCQ#TRPBF		5-Lead DD	0°C to 100°C
LT1171CQ#PBF	LT1171CQ#TRPBF		5-Lead DD	0°C to 100°C
LT1171IQ#PBF	LT1171IQ#TRPBF		5-Lead DD	-40°C to 100°C
LT1171HVCQ#PBF	LT1171HVCQ#TRPBF		5-Lead DD	0°C to 100°C
LT1171HVIQ#PBF	LT1171HVIQ#TRPBF		5-Lead DD	-40°C to 100°C
LT1172CQ#PBF	LT1172CQ#TRPBF		5-Lead DD	0°C to 100°C
LT1172HVCQ#PBF	LT1172HVCQ#TRPBF		5-Lead DD	0°C to 100°C
LT1172HVIQ#PBF	LT1172HVIQ#TRPBF		5-Lead DD	-40°C to 100°C
LT1172CSW#PBF	LT1172CSW#TRPBF		16-Lead Plastic SO Wide	0°C to 100°C
LT1170CT#PBF	LT1170CT#TRPBF		5-Lead Plastic TO-220	0°C to 100°C
LT1170IT#PBF	LT1170IT#TRPBF		5-Lead Plastic TO-220	-40°C to 100°C
LT1170HVCT#PBF	LT1170HVCT#TRPBF		5-Lead Plastic TO-220	0°C to 100°C
LT1170HVIT#PBF	LT1170HVIT#TRPBF		5-Lead Plastic TO-220	-40°C to 100°C
LT1171CT#PBF	LT1171CT#TRPBF		5-Lead Plastic TO-220	0°C to 100°C
LT1171IT#PBF	LT1171IT#TRPBF		5-Lead Plastic TO-220	-40°C to 100°C
LT1171HVCT#PBF	LT1171HVCT#TRPBF		5-Lead Plastic TO-220	0°C to 100°C
LT1171HVIT#PBF	LT1171HVIT#TRPBF		5-Lead Plastic TO-220	-40°C to 100°C
LT1172CT#PBF	LT1172CT#TRPBF		5-Lead Plastic TO-220	0°C to 100°C
LT1172HVCT#PBF	LT1172HVCT#TRPBF		5-Lead Plastic TO-220	0°C to 100°C

Consult LTC Marketing for parts specified with wider operating temperature ranges.

Consult LTC Marketing for information on non-standard lead based finish parts.

For more information on lead free part marking, go to: <http://www.linear.com/leadfree/>

For more information on tape and reel specifications, go to: <http://www.linear.com/tapeandreeel/>

# LT1170/LT1171/LT1172

**ELECTRICAL CHARACTERISTICS** The ● denotes the specifications which apply over the full operating temperature range, otherwise specifications are at  $T_A = 25^\circ\text{C}$ .  $V_{IN} = 15\text{V}$ ,  $V_C = 0.5\text{V}$ ,  $V_{FB} = V_{REF}$ , output pin open, unless otherwise noted.

SYMBOL	PARAMETER	CONDITIONS	MIN	TYP	MAX	UNITS	
$V_{REF}$	Reference Voltage	Measured at Feedback Pin $V_C = 0.8\text{V}$	●	1.224	1.244	1.264	V
				1.214	1.244	1.274	V
$I_B$	Feedback Input Current	$V_{FB} = V_{REF}$	●	350	750	nA	
					1100	nA	
$g_m$	Error Amplifier Transconductance	$\Delta I_C = \pm 25\mu\text{A}$	●	3000	4400	6000	$\mu\text{mho}$
				2400		7000	$\mu\text{mho}$
	Error Amplifier Source or Sink Current	$V_C = 1.5\text{V}$	●	150	200	350	$\mu\text{A}$
				120		400	$\mu\text{A}$
	Error Amplifier Clamp Voltage	Hi Clamp, $V_{FB} = 1\text{V}$ Lo Clamp, $V_{FB} = 1.5\text{V}$		1.80		2.30	V
				0.25	0.38	0.52	V
	Reference Voltage Line Regulation	$3\text{V} \leq V_{IN} \leq V_{MAX}$ $V_C = 0.8\text{V}$	●			0.03	%/V
$A_V$	Error Amplifier Voltage Gain	$0.9\text{V} \leq V_C \leq 1.4\text{V}$		500	800		V/V
			●		2.6	3.0	V
$I_Q$	Supply Current	$3\text{V} \leq V_{IN} \leq V_{MAX}$ , $V_C = 0.6\text{V}$			6	9	mA
			●		0.8	0.9	1.08
	Control Pin Threshold	Duty Cycle = 0		0.6		1.25	V
	Normal/Flyback Threshold on Feedback Pin			0.4	0.45	0.54	V
$V_{FB}$	Flyback Reference Voltage (Note 5)	$I_{FB} = 50\mu\text{A}$	●	15.0	16.3	17.6	V
				14.0		18.0	V
	Change in Flyback Reference Voltage	$0.05 \leq I_{FB} \leq 1\text{mA}$		4.5	6.8	9	V
	Flyback Reference Voltage Line Regulation (Note 5)	$I_{FB} = 50\mu\text{A}$ $7\text{V} \leq V_{IN} \leq V_{MAX}$			0.01	0.03	%/V
	Flyback Amplifier Transconductance ( $g_m$ )	$\Delta I_C = \pm 10\mu\text{A}$		150	300	650	$\mu\text{mho}$
	Flyback Amplifier Source and Sink Current	$V_C = 0.6\text{V}$ $I_{FB} = 50\mu\text{A}$	●	15	32	70	mA
			●	25	40	70	mA
BV	Output Switch Breakdown Voltage	$3\text{V} \leq V_{IN} \leq V_{MAX}$ , $I_{SW} = 1.5\text{mA}$	●	65	90		V
			●	75	90		V
			●	60	80		V
$V_{SAT}$	Output Switch "On" Resistance (Note 3)	LT1170 LT1171 LT1172	●		0.15	0.24	$\Omega$
			●		0.30	0.50	$\Omega$
			●		0.60	1.00	$\Omega$
	Control Voltage to Switch Current Transconductance	LT1170 LT1171 LT1172			8		A/V
					4		A/V
					2		A/V
$I_{LIM}$	Switch Current Limit	(LT1170)	Duty Cycle = 50% $T_J \geq 25^\circ\text{C}$	●	5	10	A
			Duty Cycle = 50% $T_J < 25^\circ\text{C}$	●	5	11	A
			Duty Cycle = 80% (Note 4)	●	4	10	A
		(LT1171)	Duty Cycle = 50% $T_J \geq 25^\circ\text{C}$	●	2.5	5.0	A
			Duty Cycle = 50% $T_J < 25^\circ\text{C}$	●	2.5	5.5	A
			Duty Cycle = 80% (Note 4)	●	2.0	5.0	A
		(LT1172)	Duty Cycle = 50% $T_J \geq 25^\circ\text{C}$	●	1.25	3.0	A
			Duty Cycle = 50% $T_J < 25^\circ\text{C}$	●	1.25	3.5	A
			Duty Cycle = 80% (Note 4)	●	1.00	2.5	A
$\frac{\Delta I_{IN}}{\Delta I_{SW}}$	Supply Current Increase During Switch On-Time			25	35	mA/A	
f	Switching Frequency		●	88	100	112	kHz
				85		115	kHz

**ELECTRICAL CHARACTERISTICS** The ● denotes the specifications which apply over the full operating temperature range, otherwise specifications are at  $T_A = 25^\circ\text{C}$ .  $V_{IN} = 15\text{V}$ ,  $V_C = 0.5\text{V}$ ,  $V_{FB} = V_{REF}$ , output pin open, unless otherwise noted.

SYMBOL	PARAMETER	CONDITIONS		MIN	TYP	MAX	UNITS
$DC_{MAX}$	Maximum Switch Duty Cycle		●	85	92	97	%
	Shutdown Mode Supply Current	$3\text{V} \leq V_{IN} \leq V_{MAX}$ $V_C = 0.05\text{V}$			100	250	$\mu\text{A}$
	Shutdown Mode Threshold Voltage	$3\text{V} \leq V_{IN} \leq V_{MAX}$	●	100 50	150	250 300	mV mV
	Flyback Sense Delay Time (Note 5)				1.5		$\mu\text{s}$

**Note 1:** Stresses beyond those listed under Absolute Maximum Ratings may cause permanent damage to the device. Exposure to any Absolute Maximum Rating condition for extended periods may affect device reliability and lifetime.

**Note 2:** Minimum effective switch “on” time for the LT1170/LT1171/LT1172 (in current limit only) is  $\approx 0.6\mu\text{s}$ . This limits the maximum safe input voltage during an output shorted condition. Buck mode and inverting mode input voltage during an output shorted condition is limited to:

$$V_{IN}(\text{max, output shorted}) = 15\text{V} + \frac{(R)(I_L) + V_f}{(t)(f)}$$

buck and inverting mode

R = Inductor DC resistance

$I_L = 10\text{A}$  for LT1170,  $5\text{A}$  for LT1171, and  $2.5\text{A}$  for LT1172

$V_f$  = Output catch diode forward voltage at  $I_L$

$t = 0.6\mu\text{s}$ ,  $f = 100\text{kHz}$  switching frequency

Maximum input voltage can be increased by increasing R or  $V_f$ .

External current limiting such as that shown in AN19, Figure 39, will provide protection up to the full supply voltage rating. C1 in Figure 39 should be reduced to  $200\text{pF}$ .

Transformer designs will tolerate much higher input voltages because leakage inductance limits rate of rise of current in the switch. These designs must be evaluated individually to assure that current limit is well controlled up to maximum input voltage.

Boost mode designs are never protected against output shorts because the external catch diode and inductor connect input to output.

**Note 3:** Measured with  $V_C$  in hi clamp,  $V_{FB} = 0.8\text{V}$ .  $I_{SW} = 4\text{A}$  for LT1170,  $2\text{A}$  for LT1171, and  $1\text{A}$  for LT1172.

**Note 4:** For duty cycles (DC) between 50% and 80%, minimum guaranteed switch current is given by  $I_{LIM} = 3.33(2 - DC)$  for the LT1170,  $I_{LIM} = 1.67(2 - DC)$  for the LT1171, and  $I_{LIM} = 0.833(2 - DC)$  for the LT1172.

**Note 5:** Minimum input voltage for isolated flyback mode is  $7\text{V}$ .  $V_{MAX} = 55\text{V}$  for HV grade in fully isolated mode to avoid switch breakdown.

## TYPICAL PERFORMANCE CHARACTERISTICS

### Switch Current Limit vs Duty Cycle\*

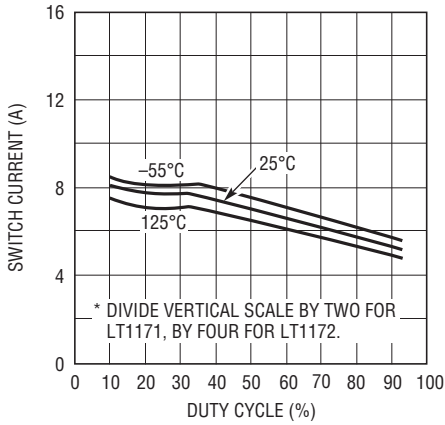

1170/1/2 G01

### Minimum Input Voltage

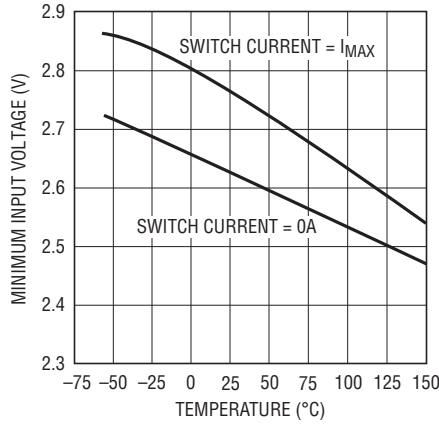

1170/1/2 G02

### Switch Saturation Voltage

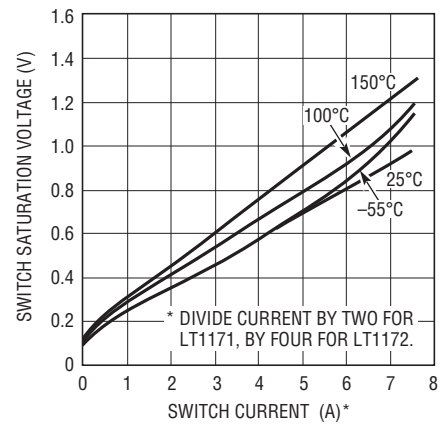

1170/1/2 G03

### Line Regulation

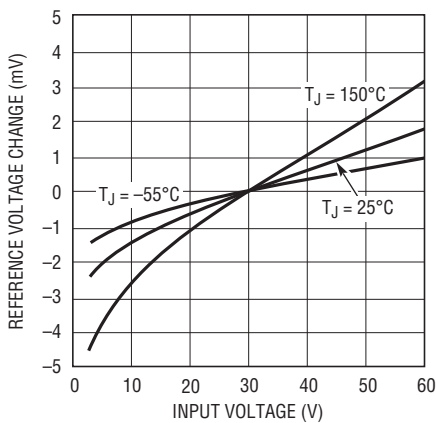

1170/1/2 G04

### Reference Voltage vs Temperature

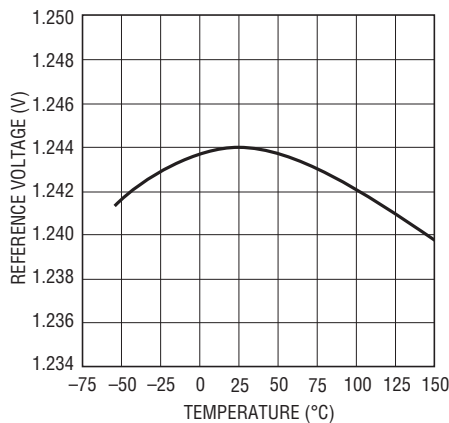

1170/1/2 G05

### Feedback Bias Current vs Temperature

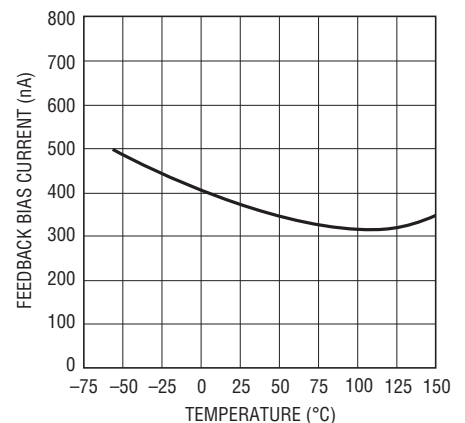

1170/1/2 G06

### Supply Current vs Supply Voltage (Shutdown Mode)

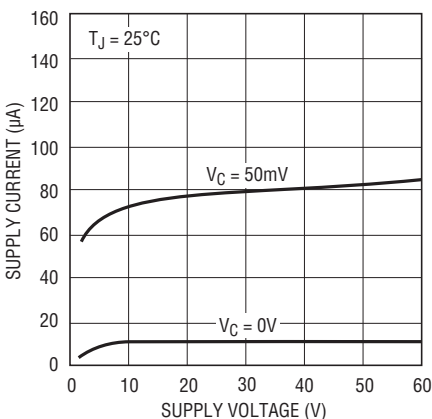

1170/1/2 G07

### Driver Current\* vs Switch Current

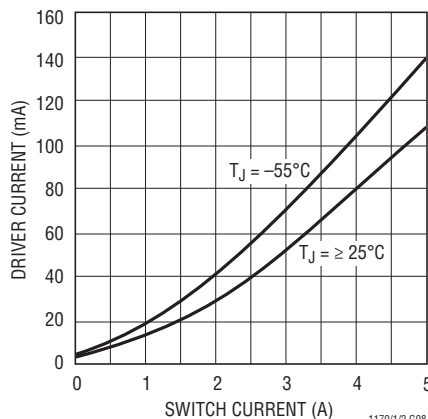

1170/1/2 G08

### Supply Current vs Input Voltage\*

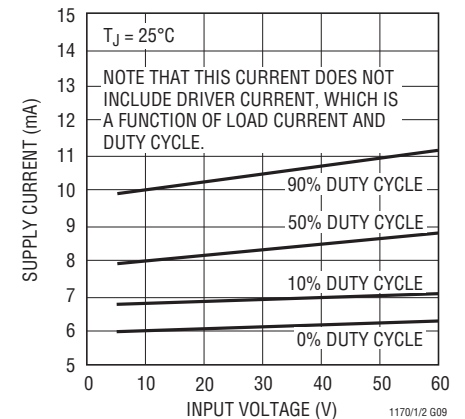

1170/1/2 G09

\* AVERAGE LT1170 POWER SUPPLY CURRENT IS FOUND BY MULTIPLYING DRIVER CURRENT BY DUTY CYCLE, THEN ADDING QUIESCENT CURRENT.

\* UNDER VERY LOW OUTPUT CURRENT CONDITIONS, DUTY CYCLE FOR MOST CIRCUITS WILL APPROACH 10% OR LESS.

117012fg

# TYPICAL PERFORMANCE CHARACTERISTICS

**Shutdown Mode Supply Current**

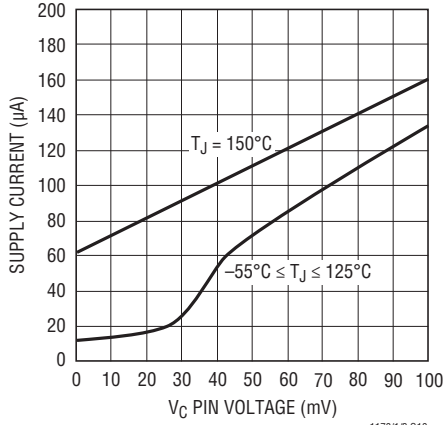

1170/1/2 G10

**Error Amplifier Transconductance**

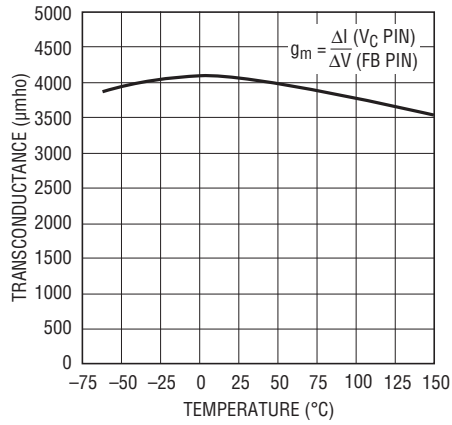

1170/1/2 G11

**Vc Pin Characteristics**

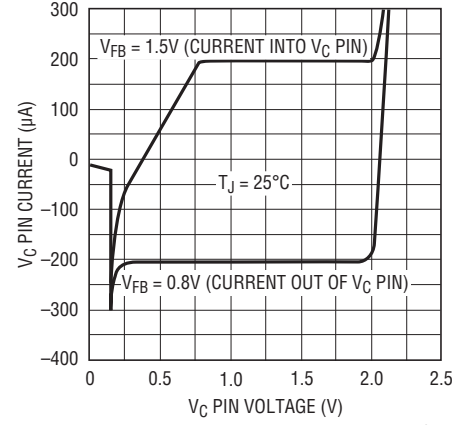

1170/1/2 G12

**Idle Supply Current vs Temperature**

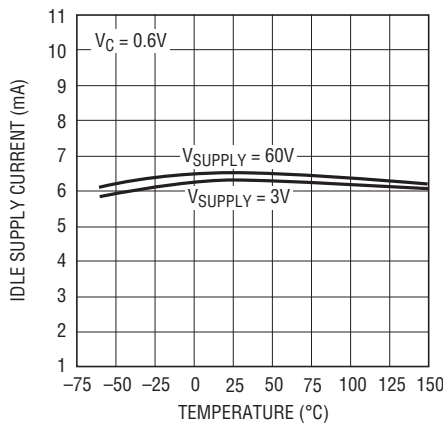

1170/1/2 G13

**Feedback Pin Clamp Voltage**

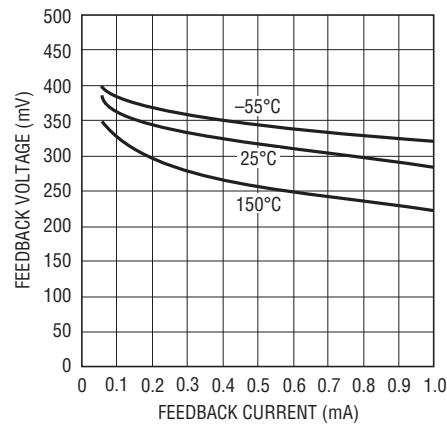

1170/1/2 G14

**Switch "Off" Characteristics**

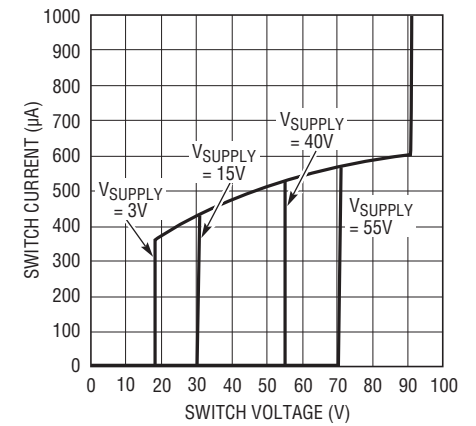

1170/1/2 G15

**Shutdown Thresholds**

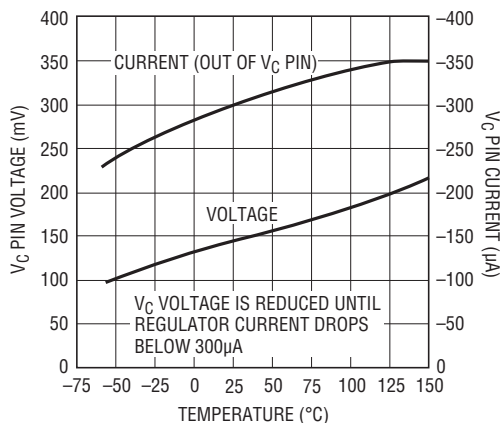

1170/1/2 G16

**Flyback Blanking Time**

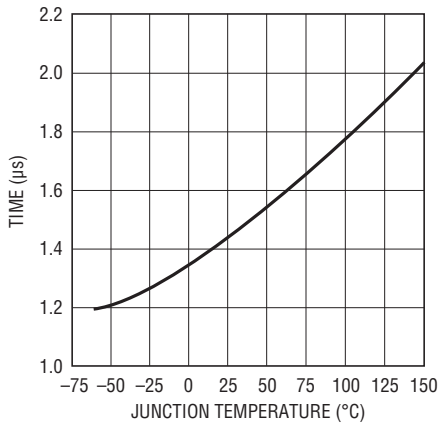

1170/1/2 G17

**Isolated Mode Flyback Reference Voltage**

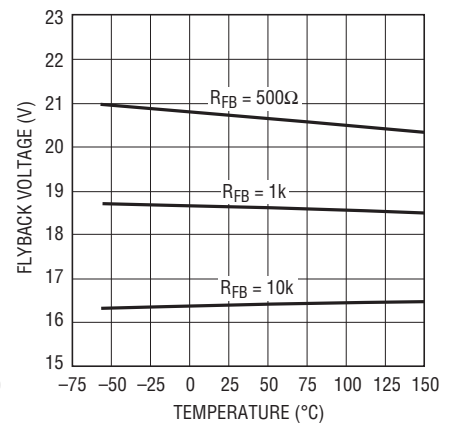

1170/1/2 G18

**TYPICAL PERFORMANCE CHARACTERISTICS**

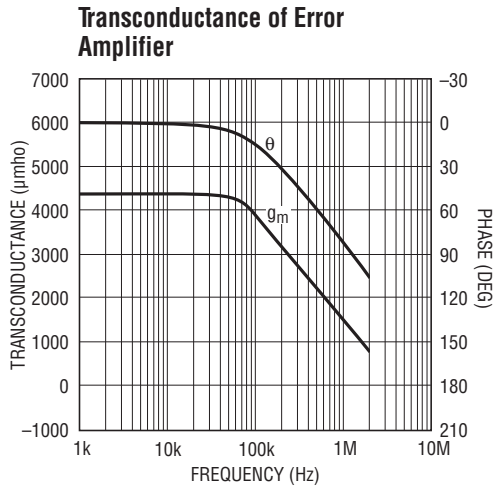

1170/1/2 G19

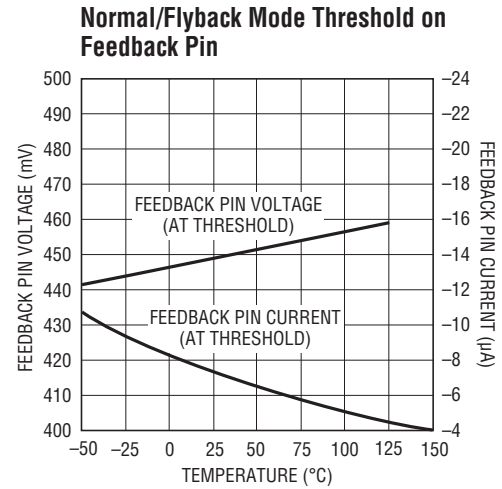

1170/1/2 G20

**BLOCK DIAGRAM**

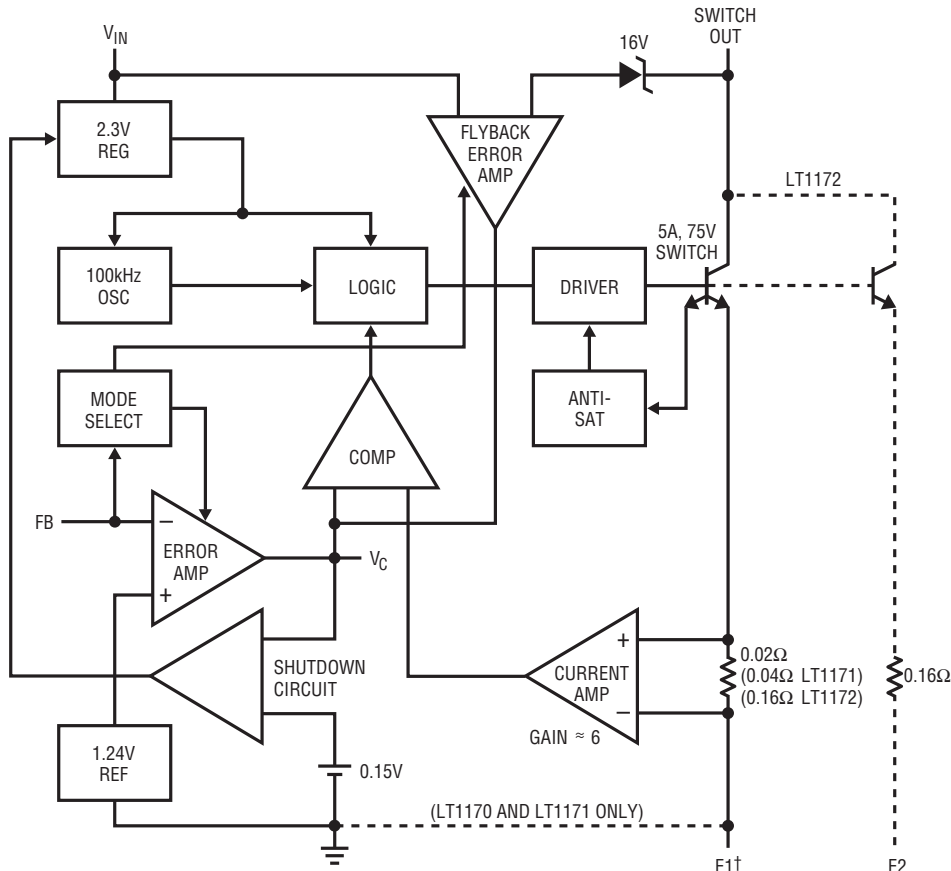

† ALWAYS CONNECT E1 TO THE GROUND PIN ON MINIDIP, 8- AND 16-PIN SURFACE MOUNT PACKAGES. E1 AND E2 INTERNALLY TIED TO GROUND ON TO-3 AND TO-220 PACKAGES.

1170/1/2 BD



## OPERATION

The LT1170/LT1171/LT1172 are current mode switchers. This means that switch duty cycle is directly controlled by switch current rather than by output voltage. Referring to the block diagram, the switch is turned “on” at the start of each oscillator cycle. It is turned “off” when switch current reaches a predetermined level. Control of output voltage is obtained by using the output of a voltage sensing error amplifier to set current trip level. This technique has several advantages. First, it has immediate response to input voltage variations, unlike ordinary switchers which have notoriously poor line transient response. Second, it reduces the 90° phase shift at midfrequencies in the energy storage inductor. This greatly simplifies closed loop frequency compensation under widely varying input voltage or output load conditions. Finally, it allows simple pulse-by-pulse current limiting to provide maximum switch protection under output overload or short conditions. A low dropout internal regulator provides a 2.3V supply for all internal circuitry on the LT1170/LT1171/LT1172. This low dropout design allows input voltage to vary from 3V to 60V with virtually no change in device performance. A 100kHz oscillator is the basic clock for all internal timing. It turns “on” the output switch via the logic and driver circuitry. Special adaptive anti-sat circuitry detects onset of saturation in the power switch and adjusts driver current instantaneously to limit switch saturation. This minimizes driver dissipation and provides very rapid turnoff of the switch.

A 1.2V bandgap reference biases the positive input of the error amplifier. The negative input is brought out for output voltage sensing. This feedback pin has a second function; when pulled low with an external resistor, it programs the LT1170/LT1171/LT1172 to disconnect the main error amplifier output and connects the output of the flyback amplifier to the comparator input. The LT1170/LT1171/LT1172 will then regulate the value of the flyback pulse with respect to the supply voltage.\* This flyback pulse is directly proportional to output voltage in the traditional transformer coupled flyback topology regulator. By regulating the amplitude of the flyback pulse, the output voltage can be regulated with no direct connection between input and output. The output is fully floating up to the breakdown voltage of the transformer windings. Multiple floating outputs are easily obtained with additional windings.

A special delay network inside the LT1170/LT1171/LT1172 ignores the leakage inductance spike at the leading edge of the flyback pulse to improve output regulation.

The error signal developed at the comparator input is brought out externally. This pin ( $V_C$ ) has four different functions. It is used for frequency compensation, current limit adjustment, soft-starting, and total regulator shutdown. During normal regulator operation this pin sits at a voltage between 0.9V (low output current) and 2.0V (high output current). The error amplifiers are current output ( $g_m$ ) types, so this voltage can be externally clamped for adjusting current limit. Likewise, a capacitor coupled external clamp will provide soft-start. Switch duty cycle goes to zero if the  $V_C$  pin is pulled to ground through a diode, placing the LT1170/LT1171/LT1172 in an idle mode. Pulling the  $V_C$  pin below 0.15V causes total regulator shutdown, with only 50 $\mu$ A supply current for shutdown circuitry biasing. See Application Note 19 for full application details.

### Extra Pins on the MiniDIP and Surface Mount Packages

The 8- and 16-pin versions of the LT1172 have the emitters of the power transistor brought out separately from the ground pin. This eliminates errors due to ground pin voltage drops and allows the user to reduce switch current limit 2:1 by leaving the second emitter (E2) disconnected. The first emitter (E1) should always be connected to the ground pin. Note that switch “on” resistance doubles when E2 is left open, so efficiency will suffer somewhat when switch currents exceed 300mA. Also, note that chip dissipation will actually *increase* with E2 open during normal load operation, even though dissipation in current limit mode will *decrease*. See “Thermal Considerations” next.

### Thermal Considerations When Using the MiniDIP and SW Packages

The low supply current and high switch efficiency of the LT1172 allow it to be used without a heat sink in most applications when the TO-220 or TO-3 package is selected. These packages are rated at 50°C/W and 35°C/W respectively. The miniDIPs, however, are rated at 100°C/W in ceramic (J) and 130°C/W in plastic (N).

\*See note under Block Diagram.

## OPERATION

Care should be taken for miniDIP applications to ensure that the worst case input voltage and load current conditions do not cause excessive die temperatures. The following formulas can be used as a rough guide to calculate LT1172 power dissipation. For more details, the reader is referred to Application Note 19 (AN19), "Efficiency Calculations" section.

Average supply current (including driver current) is:

$$I_{IN} \approx 6\text{mA} + I_{SW} (0.004 + \text{DC}/40)$$

$I_{SW}$  = switch current

DC = switch duty cycle

Switch power dissipation is given by:

$$P_{SW} = (I_{SW})^2 \cdot (R_{SW})(\text{DC})$$

$R_{SW}$  = LT1172 switch "on" resistance ( $1\Omega$  maximum)

Total power dissipation is the sum of supply current times input voltage plus switch power:

$$P_{D(\text{TOT})} = (I_{IN})(V_{IN}) + P_{SW}$$

In a typical example, using a boost converter to generate 12V at 0.12A from a 5V input, duty cycle is approximately 60%, and switch current is about 0.65A, yielding:

$$I_{IN} = 6\text{mA} + 0.65(0.004 + \text{DC}/40) = 18\text{mA}$$

$$P_{SW} = (0.65)^2 \cdot (1\Omega)(0.6) = 0.25\text{W}$$

$$P_{D(\text{TOT})} = (5\text{V})(0.018\text{A}) + 0.25 = 0.34\text{W}$$

Temperature rise in a plastic miniDIP would be  $130^\circ\text{C}/\text{W}$  times 0.34W, or approximately  $44^\circ\text{C}$ . The maximum ambient temperature would be limited to  $100^\circ\text{C}$  (commercial temperature limit) minus  $44^\circ\text{C}$ , or  $56^\circ\text{C}$ .

In most applications, full load current is used to calculate die temperature. However, if overload conditions must also be accounted for, four approaches are possible. First, if loss of regulated output is acceptable under overload conditions, the internal *thermal limit* of the LT1172 will protect the die in most applications by shutting off switch current. *Thermal limit is not a tested parameter*, however, and should be considered only for noncritical applications with temporary overloads. A second approach is to use the

larger TO-220 (T) or TO-3 (K) package which, even without a heat sink, may limit die temperatures to safe levels under overload conditions. In critical situations, heat sinking of these packages is required; especially if overload conditions must be tolerated for extended periods of time.

The third approach for lower current applications is to leave the second switch emitter (miniDIP only) open. This increases switch "on" resistance by 2:1, but reduces switch current limit by 2:1 also, resulting in a net 2:1 reduction in  $I^2R$  switch dissipation under current limit conditions.

The fourth approach is to clamp the  $V_C$  pin to a voltage less than its internal clamp level of 2V. The LT1172 switch current limit is zero at approximately 1V on the  $V_C$  pin and 2A at 2V on the  $V_C$  pin. Peak switch current can be externally clamped between these two levels with a diode. See AN19 for details.

### LT1170/LT1171/LT1172 Synchronizing

The LT1170/LT1171/LT1172 can be externally synchronized in the frequency range of 120kHz to 160kHz. This is accomplished as shown in the accompanying figures. Synchronizing occurs when the  $V_C$  pin is pulled to ground with an external transistor. To avoid disturbing the DC characteristics of the internal error amplifier, the width of the synchronizing pulse should be under  $0.3\mu\text{s}$ .  $C_2$  sets the pulse width at  $\approx 0.2\mu\text{s}$ . The effect of a synchronizing pulse on the LT1170/LT1171/LT1172 amplifier offset can be calculated from:

$$\Delta V_{OS} = \frac{\left(\frac{KT}{q}\right)(t_s)(f_s)\left(I_C + \frac{V_C}{R_3}\right)}{I_C}$$

$$\frac{KT}{q} = 26\text{mV at } 25^\circ\text{C}$$

$t_c$  = pulse width

$f_s$  = pulse frequency

$I_C$  =  $V_C$  source current ( $\approx 200\mu\text{A}$ )

$V_C$  = operating  $V_C$  voltage (1V to 2V)

$R_3$  = resistor used to set mid-frequency "zero" in frequency compensation network.

## OPERATION

With  $t_S = 0.2\mu s$ ,  $f_S = 150kHz$ ,  $V_C = 1.5V$ , and  $R_3 = 2k$ , offset voltage shift is  $\approx 3.8mV$ . This is not particularly bothersome, but note that high offsets could result if  $R_3$  were reduced to a much lower value. Also, the synchronizing

transistor must sink higher currents with low values of  $R_3$ , so larger drives may have to be used. The transistor must be capable of pulling the  $V_C$  pin to within 200mV of ground to ensure synchronizing.

Synchronizing with Bipolar Transistor

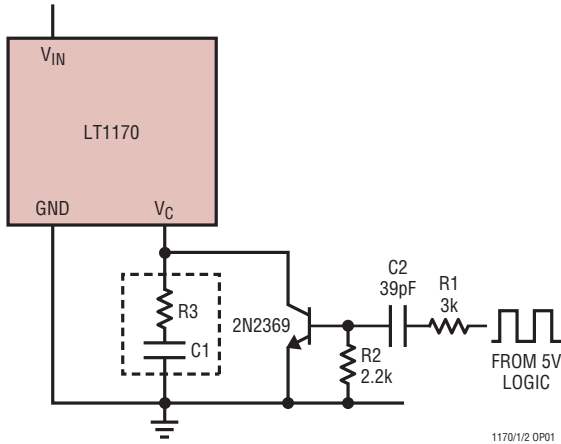

Synchronizing with MOS Transistor

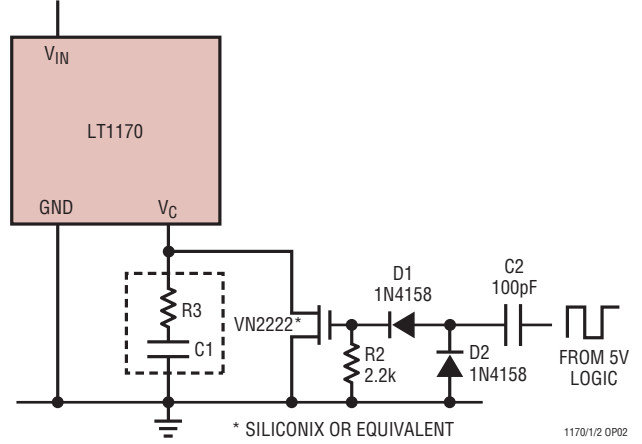

## TYPICAL APPLICATIONS

Flyback Converter

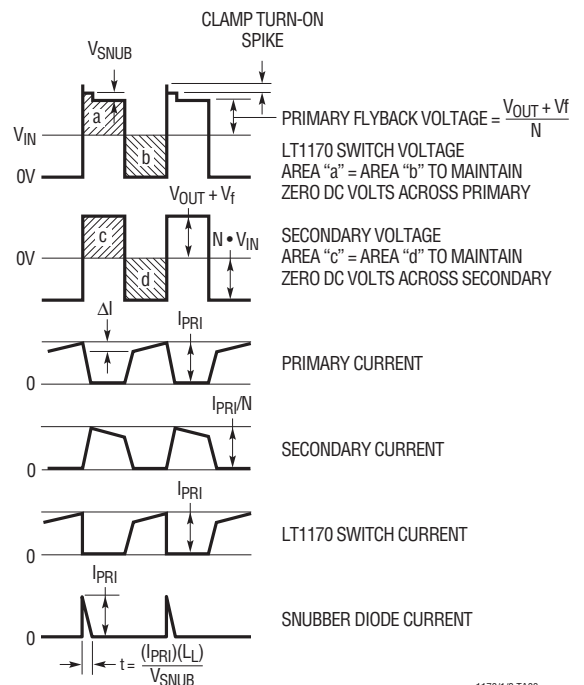
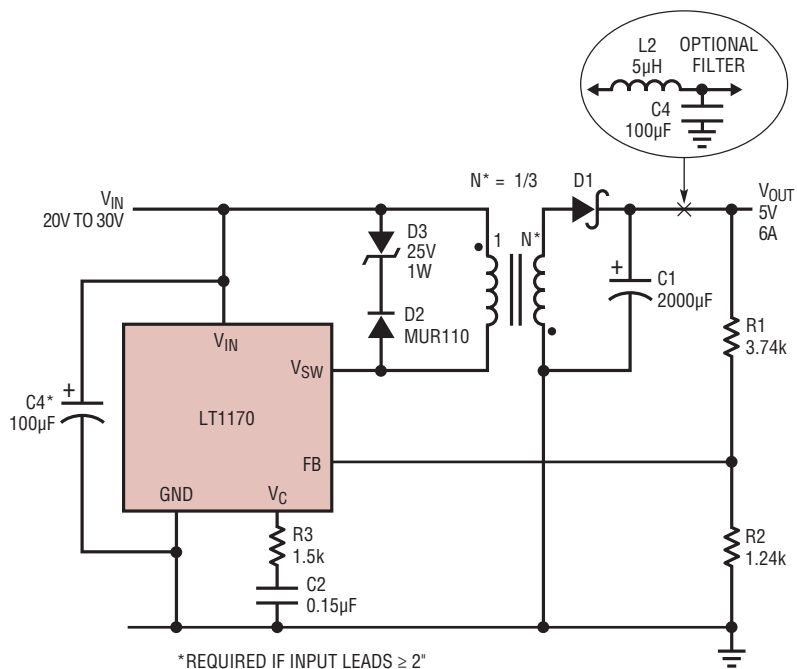

1170/1/2 TA03

117012fg

## TYPICAL APPLICATIONS (Note that maximum output currents are divided by 2 for LT1171, by 4 for LT1172.)

### LCD Contrast Supply

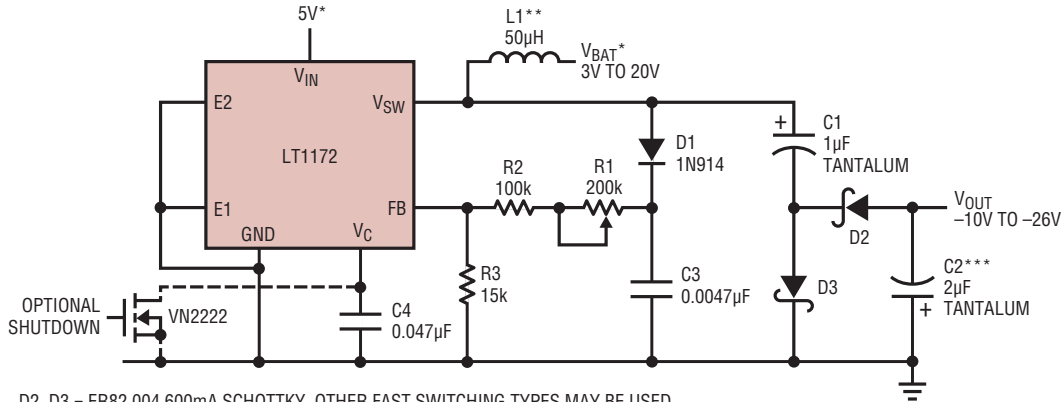

D2, D3 = ER82.004 600mA SCHOTTKY. OTHER FAST SWITCHING TYPES MAY BE USED.

\*  $V_{IN}$  AND BATTERY MAY BE TIED TOGETHER. MAXIMUM VALUE FOR  $V_{BAT}$  IS EQUAL TO THE |NEGATIVE OUTPUT| + 1V. WITH HIGHER BATTERY VOLTAGES, HIGHEST EFFICIENCY IS OBTAINED BY RUNNING THE LT1172  $V_{IN}$  PIN FROM 5V. SHUTTING OFF THE 5V SUPPLY WILL AUTOMATICALLY TURN OFF THE LT1172. EFFICIENCY IS ABOUT 80% AT  $I_{OUT} = 25mA$ .

R1, R2, R3 ARE MADE LARGE TO MINIMIZE BATTERY DRAIN IN SHUTDOWN, WHICH IS APPROXIMATELY  $V_{BAT} / (R1 + R2 + R3)$ .

\*\* FOR HIGH EFFICIENCY, L1 SHOULD BE MADE ON A FERRITE OR MOLYPERMALLOY CORE. PEAK INDUCTOR CURRENTS ARE ABOUT 600mA AT  $P_{OUT} = 0.7W$ . INDUCTOR SERIES RESISTANCE SHOULD BE LESS THAN  $0.4\Omega$  FOR HIGH EFFICIENCY.

\*\*\* OUTPUT RIPPLE IS ABOUT 200mV<sub>p-p</sub> TO 400mV<sub>p-p</sub> WITH C2 = 2µF TANTALUM. IF LOWER RIPPLE IS DESIRED, INCREASE C2, OR ADD A 10Ω, 1µF TANTALUM OUTPUT FILTER.

1170/1/2 TA04

### Driving High Voltage FET (for Off-Line Applications, See AN25)

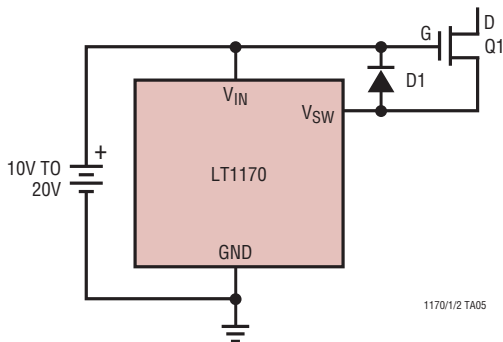

1170/1/2 TA05

### External Current Limit

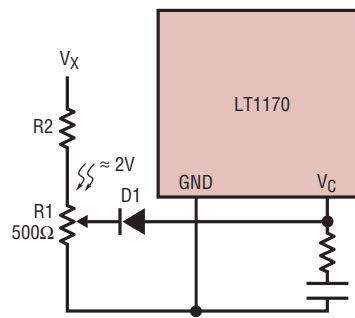

1170/1/2 TA06

**TYPICAL APPLICATIONS** (Note that maximum output currents are divided by 2 for LT1171, by 4 for LT1172.)

**Negative-to-Positive Buck-Boost Converter†**

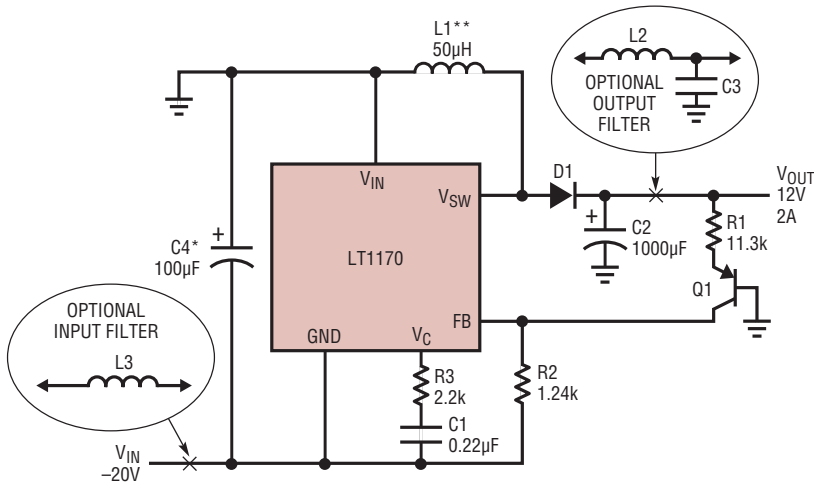

\* REQUIRED IF INPUT LEADS  $\geq 2'$   
 \*\* PULSE ENGINEERING 92114, COILTRONICS 50-2-52  
 † THIS CIRCUIT IS OFTEN USED TO CONVERT  $-48V$  TO  $5V$ . TO GUARANTEE FULL SHORT-CIRCUIT PROTECTION, THE CURRENT LIMIT CIRCUIT SHOWN IN AN19, FIGURE 39, SHOULD BE ADDED WITH  $C1$  REDUCED TO  $200pF$ .

1170/1/2 TA07

**External Current Limit**

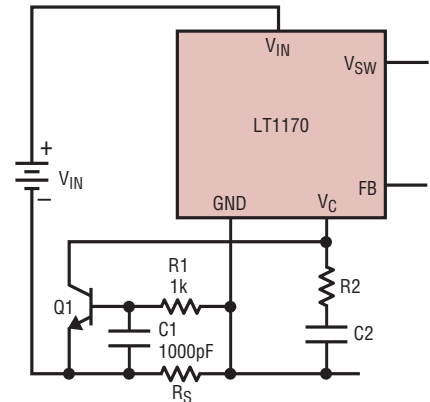

NOTE THAT THE LT1170 GND PIN IS NO LONGER COMMON TO  $V_{IN}$ .

1170/1/2 TA08

**Negative Buck Converter**

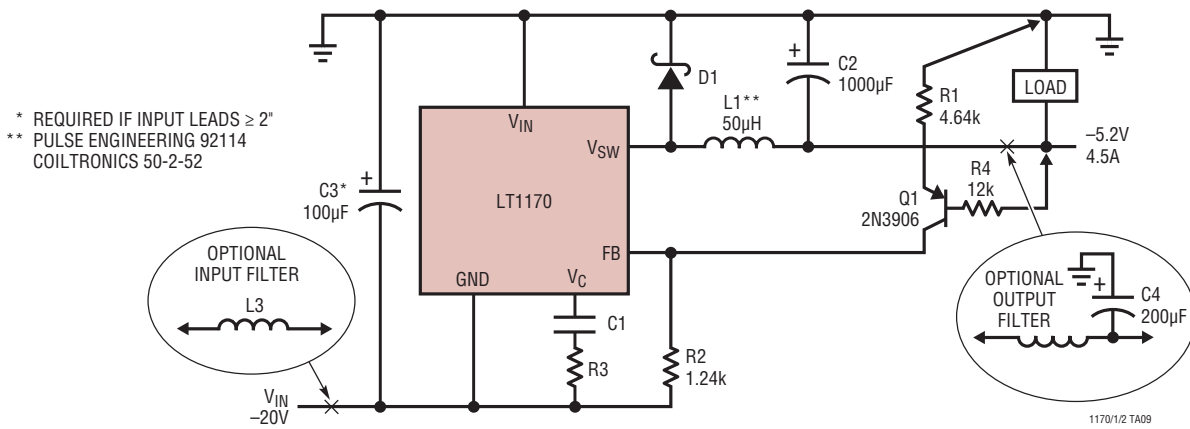

\* REQUIRED IF INPUT LEADS  $\geq 2'$   
 \*\* PULSE ENGINEERING 92114 COILTRONICS 50-2-52

1170/1/2 TA09

## TYPICAL APPLICATIONS

### Positive-to-Negative Buck-Boost Converter

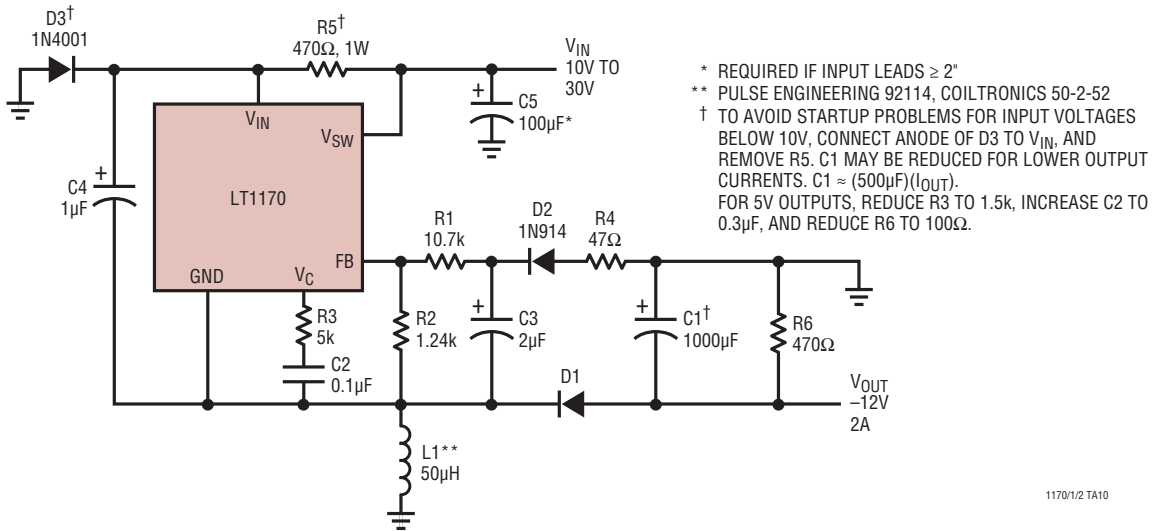

### High Efficiency Constant Current Charger

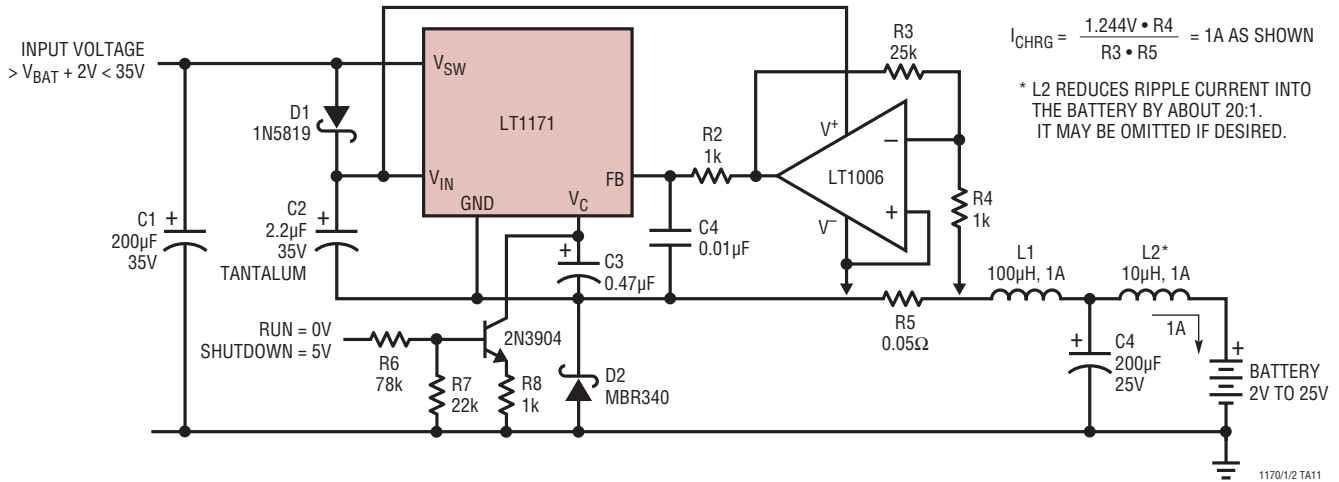

### Backlight CCFL Supply (see AN45 for details)

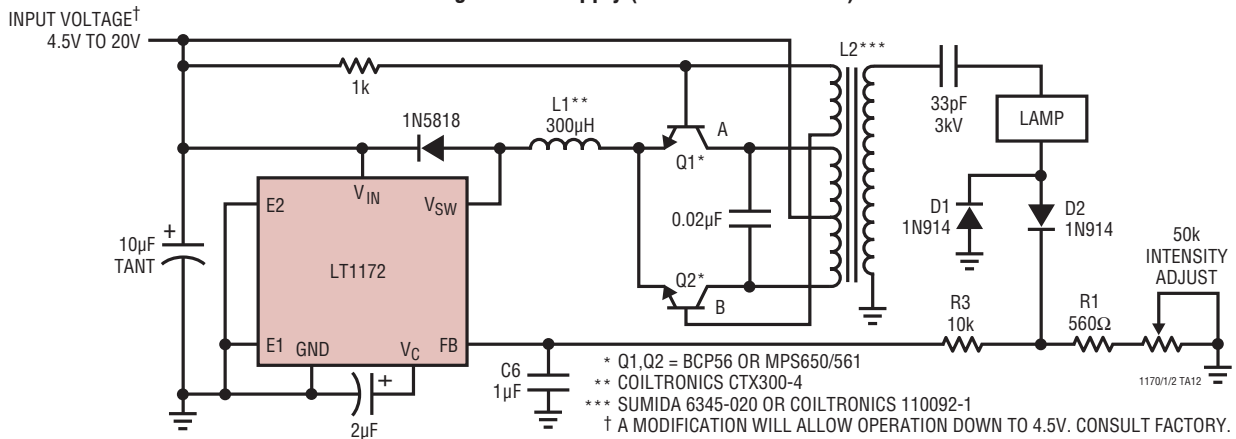

TYPICAL APPLICATIONS

Positive Buck Converter

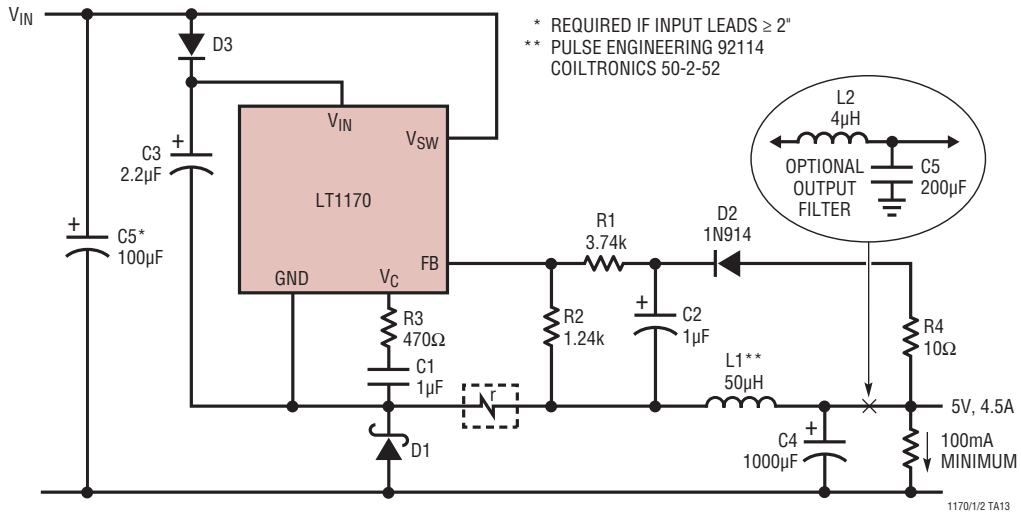

Negative Boost Regulator

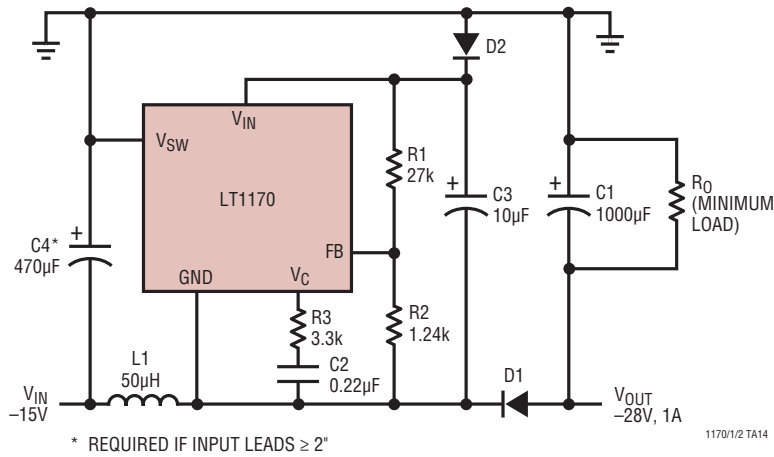

Driving High Voltage NPN

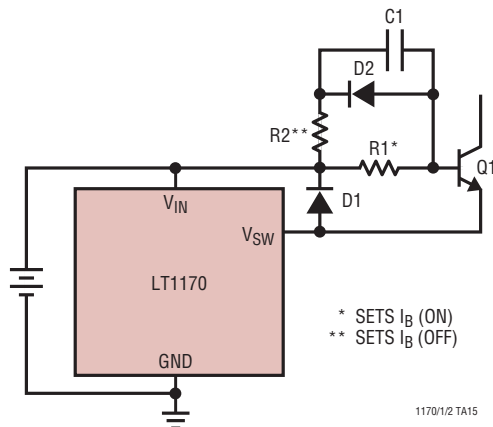

## TYPICAL APPLICATIONS

### Forward Converter

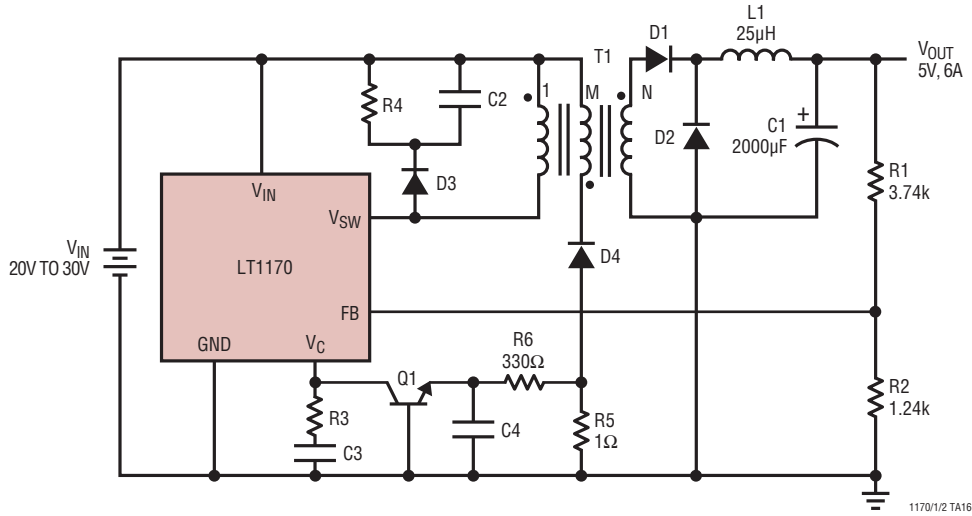

### High Efficiency 5V Buck Converter

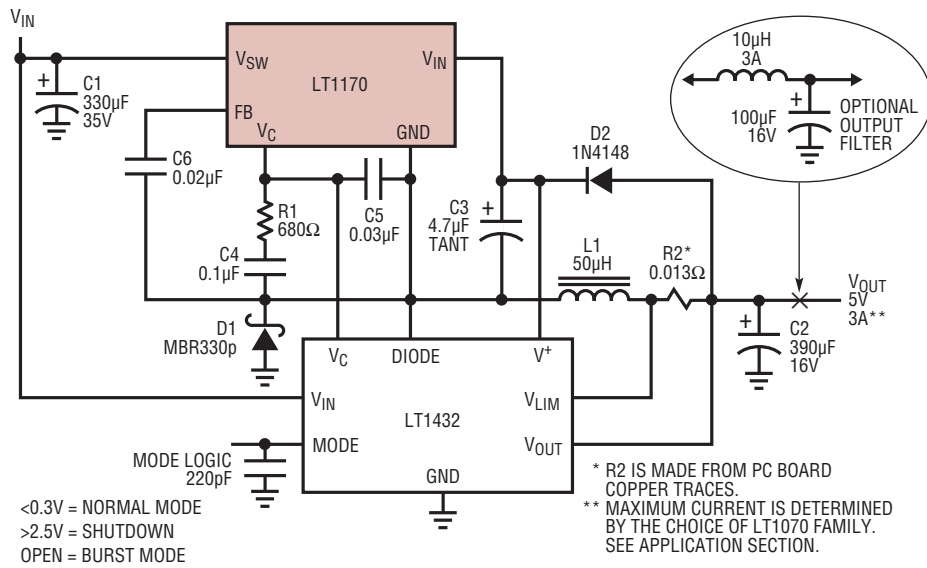



**PACKAGE DESCRIPTION**

**J8 Package**  
**8-Lead CERDIP (Narrow .300 Inch, Hermetic)**  
 (Reference LTC DWG # 05-08-1110)

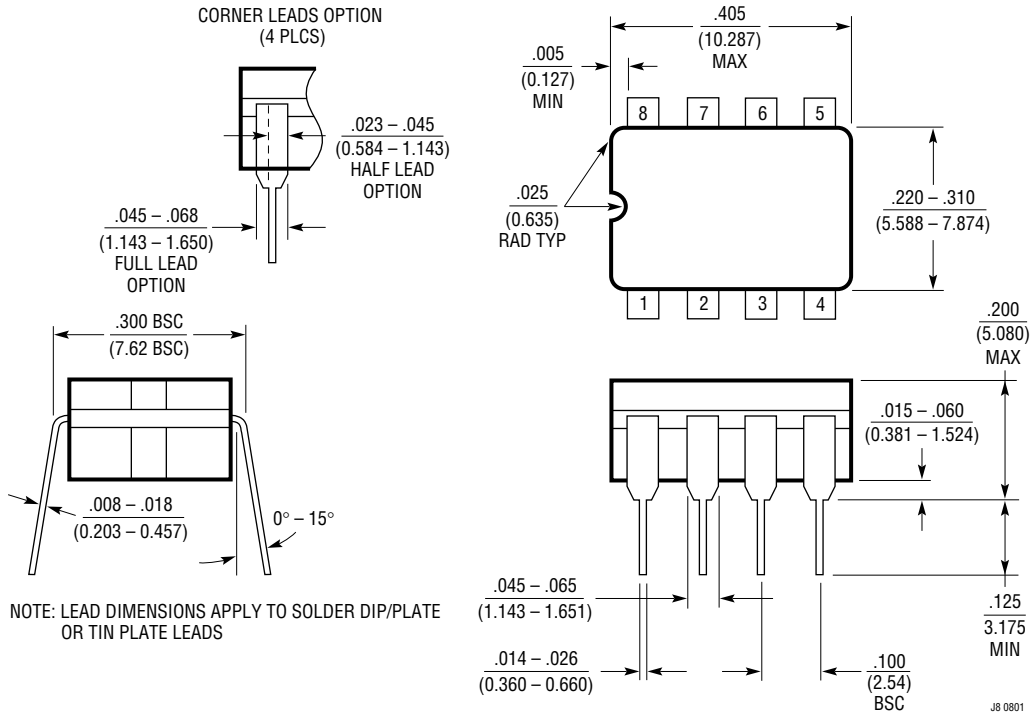

**K Package**  
**4-Lead TO-3 Metal Can**  
 (Reference LTC DWG # 05-08-1311)

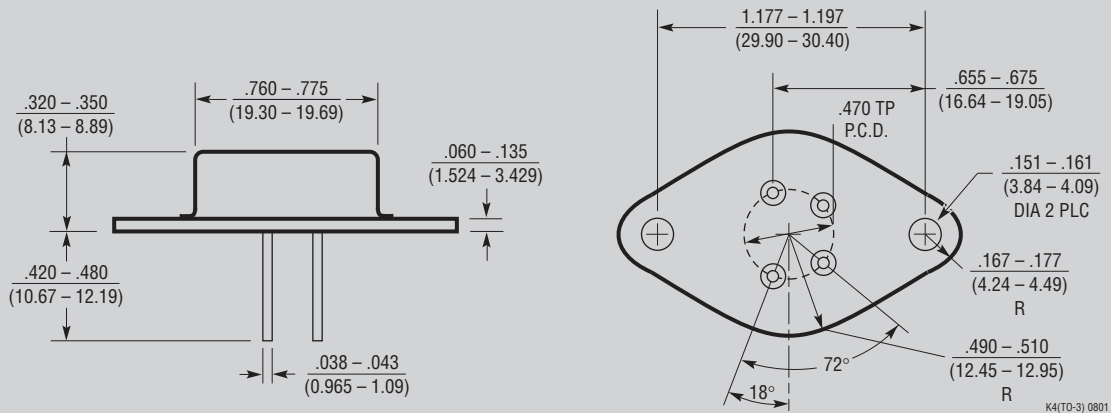

**(OBSOLETE PACKAGE)**

**PACKAGE DESCRIPTION**

**N8 Package**  
**8-Lead PDIP (Narrow .300 Inch)**  
 (Reference LTC DWG # 05-08-1510)

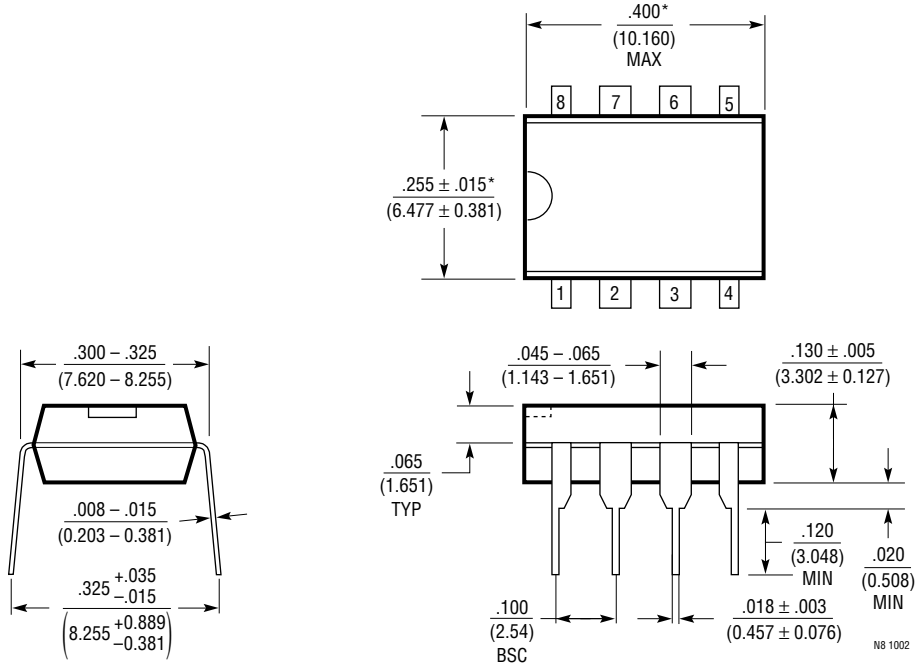

NOTE:  
 1. DIMENSIONS ARE  $\frac{\text{INCHES}}{\text{MILLIMETERS}}$   
 \*THESE DIMENSIONS DO NOT INCLUDE MOLD FLASH OR PROTRUSIONS.  
 MOLD FLASH OR PROTRUSIONS SHALL NOT EXCEED .010 INCH (0.254mm)

**PACKAGE DESCRIPTION**

**Q Package**  
**5-Lead Plastic DD Pak**  
 (Reference LTC DWG # 05-08-1461)

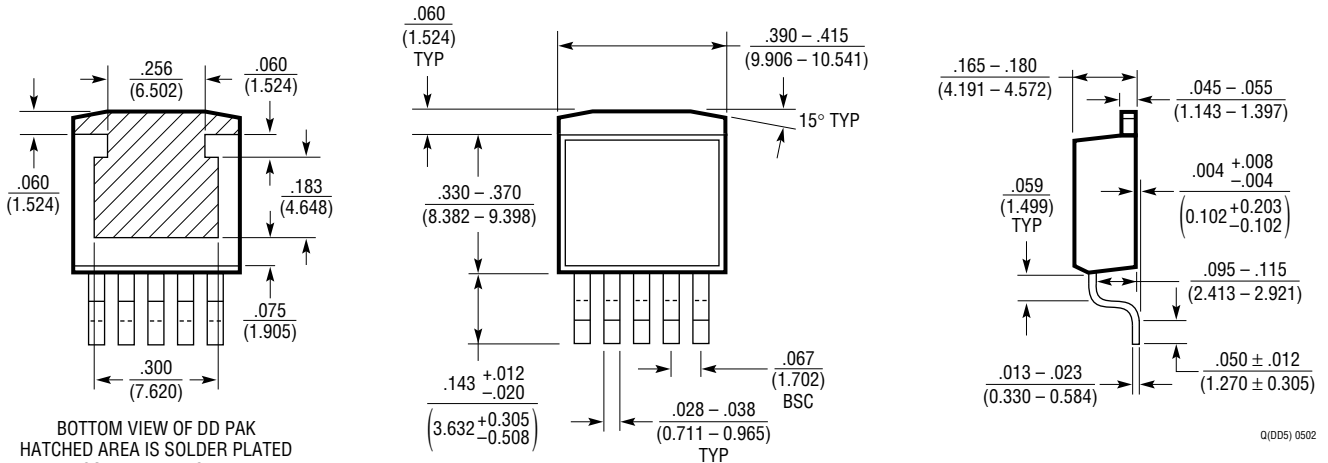

BOTTOM VIEW OF DD PAK  
 HATCHED AREA IS SOLDER PLATED  
 COPPER HEAT SINK

Q(DD5) 0502

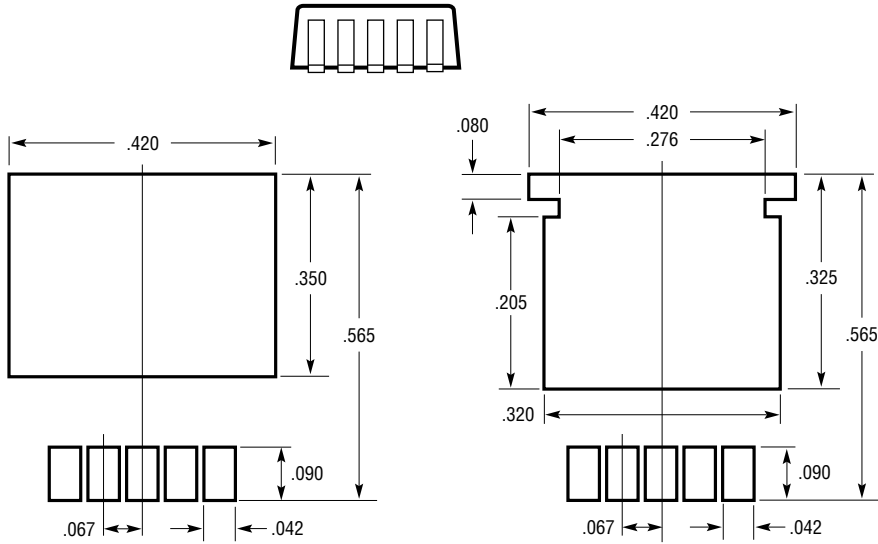

RECOMMENDED SOLDER PAD LAYOUT

NOTE:  
 1. DIMENSIONS IN INCH/(MILLIMETER)  
 2. DRAWING NOT TO SCALE

RECOMMENDED SOLDER PAD LAYOUT  
 FOR THICKER SOLDER PASTE APPLICATIONS

**PACKAGE DESCRIPTION**

**S8 Package**  
**8-Lead Plastic Small Outline (Narrow .150 Inch)**  
 (Reference LTC DWG # 05-08-1610)

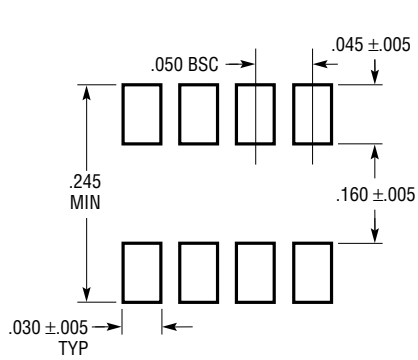

RECOMMENDED SOLDER PAD LAYOUT

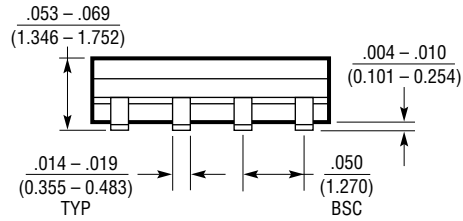
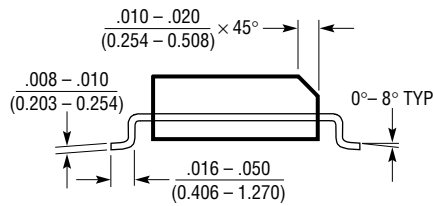
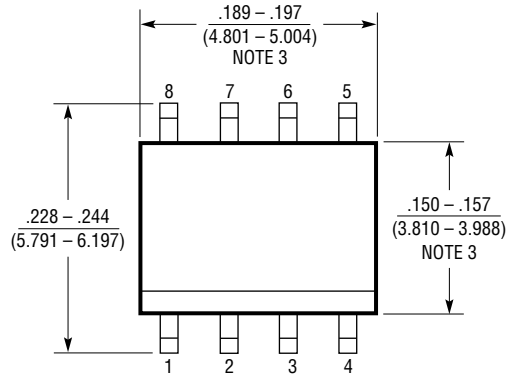

- NOTE:  
 1. DIMENSIONS IN INCHES (MILLIMETERS)  
 2. DRAWING NOT TO SCALE  
 3. THESE DIMENSIONS DO NOT INCLUDE MOLD FLASH OR PROTRUSIONS.  
 MOLD FLASH OR PROTRUSIONS SHALL NOT EXCEED .006" (0.15mm)

S08 0303

**PACKAGE DESCRIPTION**

**SW Package**  
**16-Lead Plastic Small Outline (Wide .300 Inch)**  
 (Reference LTC DWG # 05-08-1620)

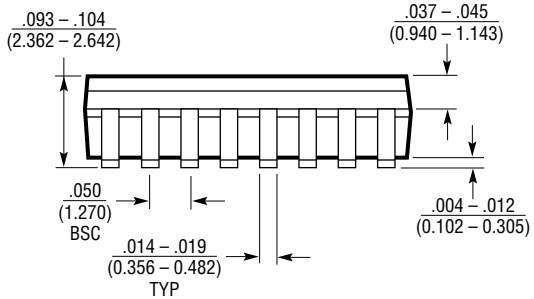
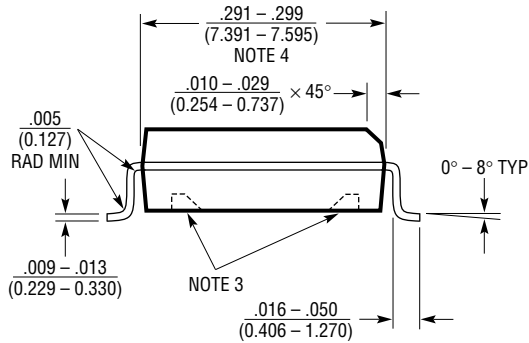
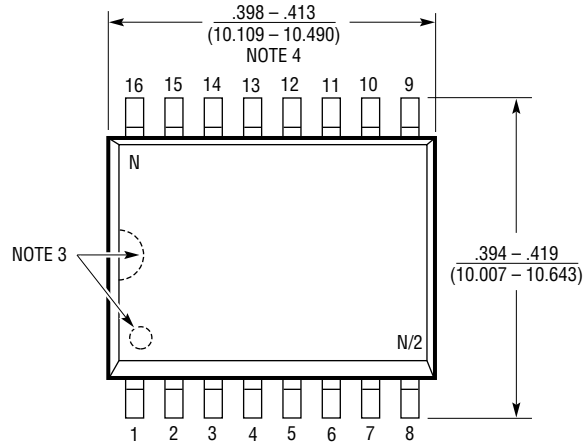
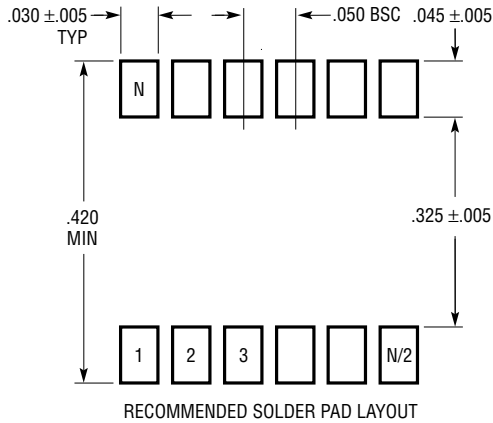

- NOTE:
1. DIMENSIONS IN  $\frac{\text{INCHES}}{\text{MILLIMETERS}}$
  2. DRAWING NOT TO SCALE
  3. PIN 1 IDENT, NOTCH ON TOP AND CAVITIES ON THE BOTTOM OF PACKAGES ARE THE MANUFACTURING OPTIONS. THE PART MAY BE SUPPLIED WITH OR WITHOUT ANY OF THE OPTIONS
  4. THESE DIMENSIONS DO NOT INCLUDE MOLD FLASH OR PROTRUSIONS. MOLD FLASH OR PROTRUSIONS SHALL NOT EXCEED .006" (0.15mm)

S16 (WIDE) 0502

**PACKAGE DESCRIPTION**

**T Package**  
**5-Lead Plastic TO-220 (Standard)**  
 (Reference LTC DWG # 05-08-1421)

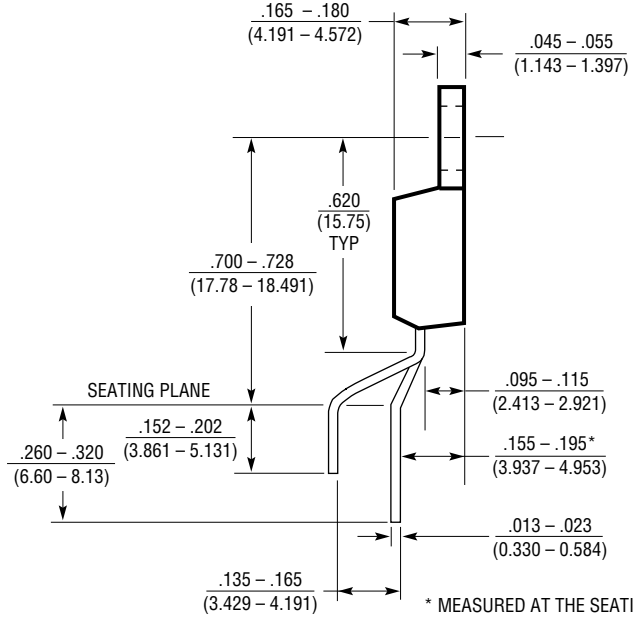
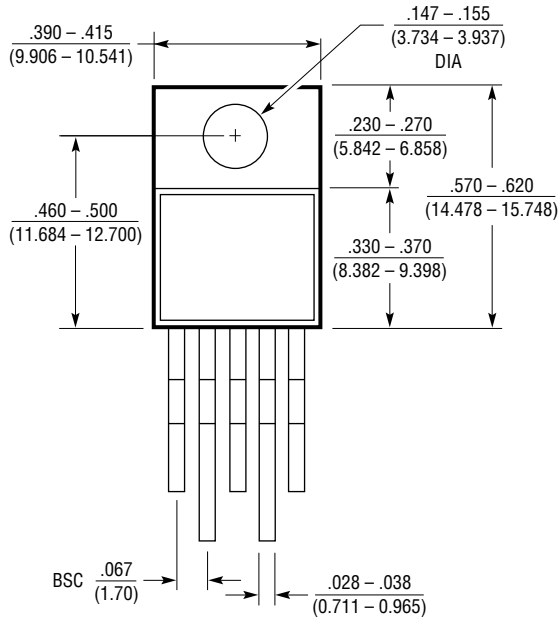

T5 (TO-220) 0801

**REVISION HISTORY** (Revision history begins at Rev G)

REV	DATE	DESCRIPTION	PAGE NUMBER
G	3/10	Updated to Reactivate LT1172M from Obsolete Parts List	2

# LT1170/LT1171/LT1172

## TYPICAL APPLICATION

### Positive Current Boosted Buck Converter

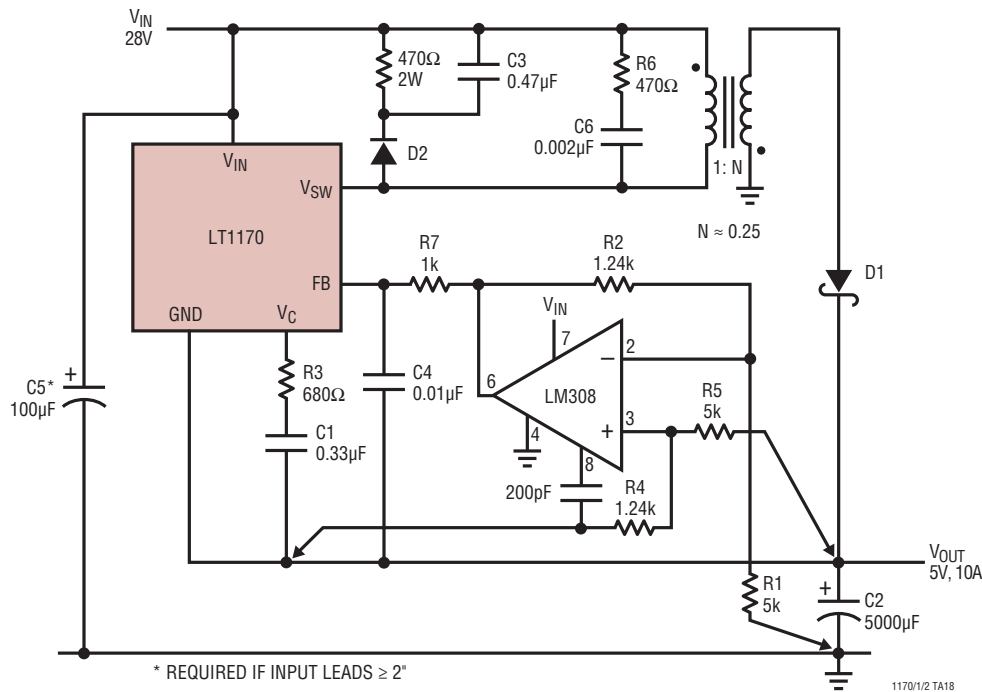

## RELATED PARTS

PART NUMBER	DESCRIPTION	COMMENTS
LT1070/LT1071/LT1072	5A/2.5A/1.25A High Efficiency Switching Regulators	40kHz, $V_{IN}$ to 60V, $V_{SW}$ to 75V
LT1074/LT1076	5.5A/2A Step-Down Switching Regulators	100kHz, Also for Positive-to-Negative Conversion
LT1082	1A, High Voltage, High Efficiency Switching Regulator	$V_{IN}$ to 75V, $V_{SW}$ to 100V, Telecom
LT1268/LT1268B	7.5A, 150kHz Switching Regulators	$V_{IN}$ to 30V, $V_{SW}$ to 60V
LT1269/LT1271	4A High Efficiency Switching Regulators	100kHz/60kHz, $V_{IN}$ to 30V, $V_{SW}$ to 60V
LT1270/LT1270A	8A and 10A High Efficiency Switching Regulators	60kHz, $V_{IN}$ to 30V, $V_{SW}$ to 60V
LT1370	500kHz High Efficiency 6A Switching Regulator	High Power Boost, Flyback, SEPIC
LT1371	500kHz High Efficiency 3A Switching Regulator	Good for Boost, Flyback, Inverting, SEPIC
LT1372/LT1377	500kHz and 1MHz High Efficiency 1.5A Switching Regulators	Directly Regulates $\pm V_{OUT}$
LT1373	250kHz Low Supply Current High Efficiency 1.5A Switching Regulator	Low 1mA Quiescent Current
LT1374	4A, 500kHz Step-Down Switching Regulator	Synchronizable, $V_{IN}$ to 25V
LT1375/LT1376	1.5A, 500kHz Step-Down Switching Regulators	Up to 1.25A Out from an SO-8
LT1425	Isolated Flyback Switching Regulator	6W Output, $\pm 5\%$ Regulation, No Optocoupler Needed
LT1507	500kHz Monolithic Buck Mode Switching Regulator	1.5A Switch, Good for 5V to 3.3V
LT1533	Ultralow Noise 1A Switching Regulator	Push-Pull, $<100\mu V_{P-P}$ Output Noise

117012fg