

SWITCH-MODE DRIVER FOR DC MOTORS

- DRIVING CAPABILITY : 2 A, 36 V, 30 KHz
- 2 LOGIC CHIP ENABLE
- EXTERNAL LOOP GAIN ADJUSTEMENT
- SINGLE POWER SUPPLY (18 TO 36 V)
- INPUT SIGNAL SYMMETRIC TO GROUND
- THERMAL PROTECTION

DESCRIPTION

The L292 is a monolithic LSI circuit in 15-lead Multiwatt® package. It is intended for use, together with L290 and L291, as a complete **3-chip motor positioning system** for applications such as carriage/daisy-wheel position control in type-writes.

The L290/1/2 system can be directly controlled by a microprocessor.

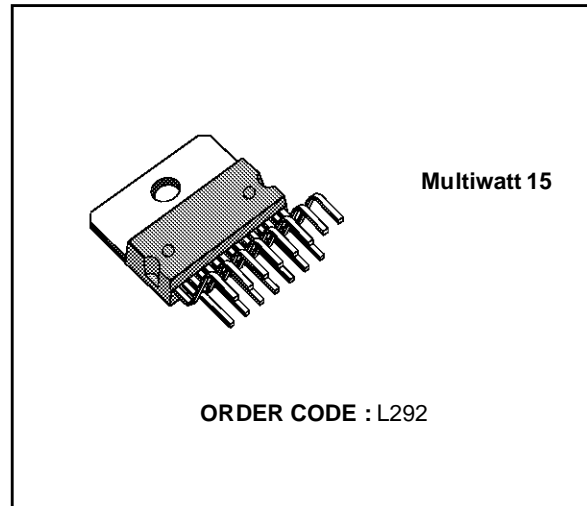

ABSOLUTE MAXIMUM RATINGS

Symbol	Parameter	Value	Unit
V_s	Power Supply	36	V
V_i	Input Voltage	- 15 to + V_s	V
$V_{inhibit}$	Inhibit Voltage	0 to V_s	V
I_o	Output Current	2.5	A
P_{tot}	Total Power Dissipation ($T_{case} = 75^\circ C$)	25	W
T_{stg}	Storage and Junction Temperature	- 40 to + 150	$^\circ C$

TRUTH TABLE

V _{inhibit}		Output Stage Condition
Pin 12	Pin 13	
L	L	Disabled
L	H	Normal Operation
H	L	Disabled
H	H	Disabled

CONNECTION DIAGRAM (top view)

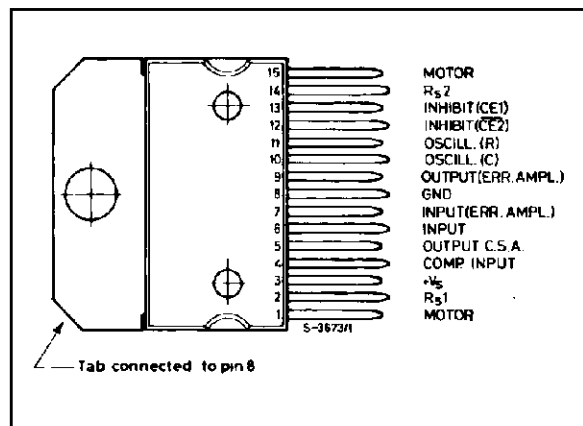

L292

THERMAL DATA

Symbol	Parameter	Value	Unit
Rth-j-case	Thermal resistance junction-case	Max 3	°C/W

ELECTRICAL CHARACTERISTICS (V_s = 36 V, T_{amb} = 25 °C, f_{osc} = 20 KHz unless otherwise specified)

Symbol	Parameter	Test conditions	Min.	Typ.	Max.	Unit
V _s	Supply Voltage		18		36	V
I _d	Quiescent Drain Current	V _s = 20 V (offset null)		30	50	mA
V _{os}	Input Offset Voltage (pin 6)	I _o = 0			±350	mV
V _{inh}	Inhibit Low Level (pin 12, 13)				2	V
	Inhibit High Level (pin 12, 13)		3.2			V
I _{inh}	Low Voltage Condition	V _{inh(L)} = 0.4 V			-100	μA
	High Voltage Conditions	V _{inh(H)} = 3.2 V			10	μA
I _i	Input Current (pin 6)	V _i = -8.8 V V _i = +8.8 V			-1.8 0.5	mA mA
V _i	Input Voltage (pin 6)	R _{s1} = R _{s2} = 0.2Ω	I _o = 2A		9.1	V
			I _o = -2A		-9.1	V
I _o	Output Current	V _i = ± 9.8 V R _{s1} = R _{s2} = 0.2 Ω	± 2			A
V _D	Total Drop Out Voltage	(including sensing resistors)	I _o = 2 A		5	V
			I _o = 1 A		3.5	V
V _{RS}	Sensing Resistor Voltage Drop	T _j = 150°C I _o = 2 A			0.44	V
I _o / V _i	Transconductance	R _{s1} = R _{s2} = 0.2Ω	205	220	235	mA/V
		R _{s1} = R _{s2} = 0.4Ω		120		mA/V
f _{osc}	Frequency Range (pin 10)		1		30	KHz

BLOCK DIAGRAM AND TEST CIRCUIT

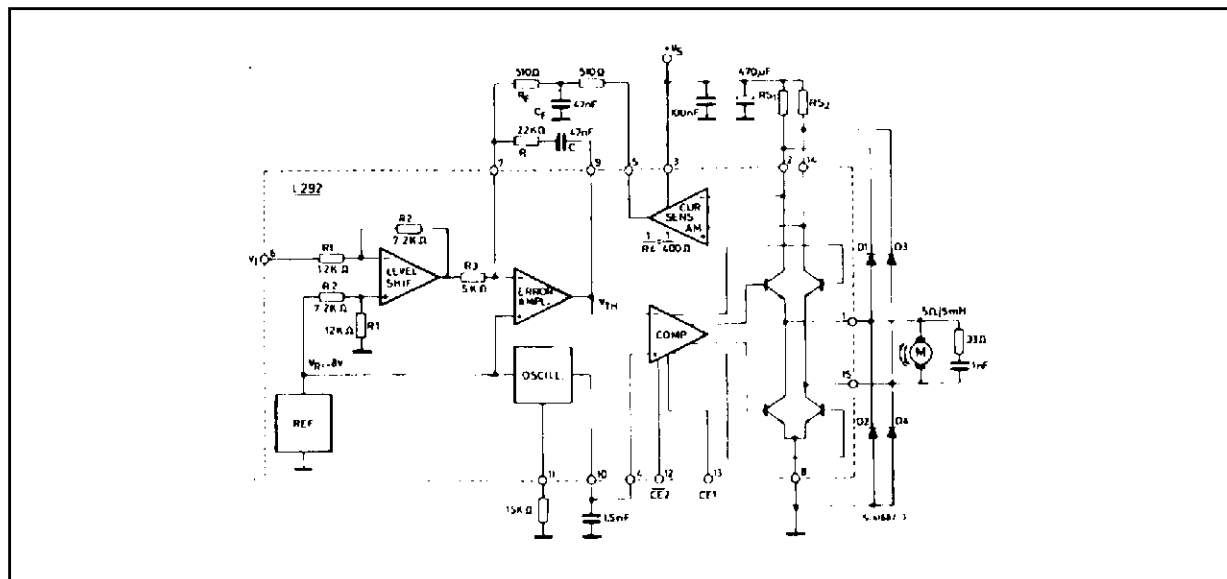

SYSTEM DESCRIPTION

The L290, L291 and L292 are intended to be used as a 3-chip microprocessor controlled positioning system. The device may be used separately - particularly the L292 motor driver - but since they will usually be used together, a description of a typical L290/1/2 system follows.

At the time, the microprocessor orders a switch to the position mode, (strobe signal at pin 8 of L291) and within 3 to 4 ms the L292 drives the motor to a null position, where it is held by electronic "de-tenting".

The mechanical/electrical interface consists of an

Figure 1. System Block Diagram

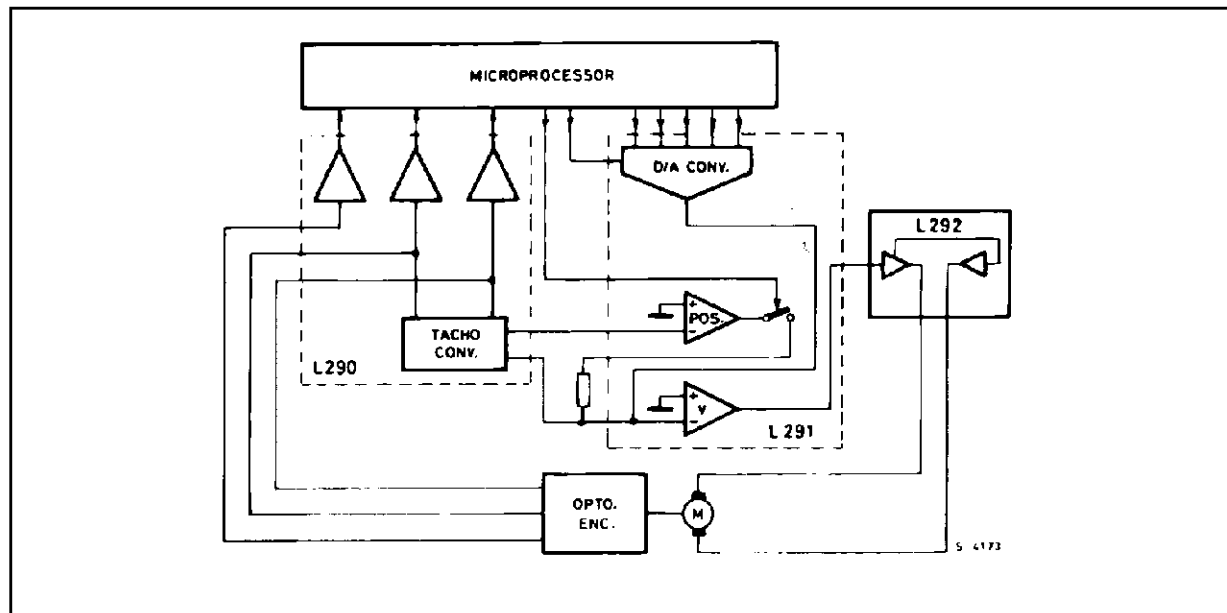

The system operates in two modes to achieve high speed, high-accuracy positioning.

Speed commands for the system originate in the microprocessor. It is continuously updated on the motor position by means of pulses from the L290 tachometer chip, which in turn gets its information from the optical encoder. From this basic input, the microprocessor computes a 5-bit control word that sets the system speed dependent on the distance to travel.

When the motor is stopped and the microprocessor orders it to a new position, the system operates initially in an open-loop configuration as there is no feedback from the tachometer generator. A maximum speed is reached, the tachometer chip output backs off the processor signal thus reducing accelerating torque. The motor continues to run at top speed but under closed-loop control.

As the target position is approached, the microprocessor lowers the value of the speed-demand word; this reduces the voltage at the main summing point, in effect braking the motor. The braking is applied progressively until the motor is running at minimum speed.

optical encoder which generates two sinusoidal signals 90° out of phase (leading according to the motor direction) and proportional in frequency to the speed of rotation. The optical encoder also provides an output at one position on the disk which is used to set the initial position.

The opto encoder signals, FTA and FTB are filtered by the networks R_2C_2 and R_3C_3 (referring to Fig.4) and are supplied to the FTA/FTB inputs on the L290. The main function on the L290 is to implement the following expression:

$$\text{Output signal (TACHO)} = \frac{dV_{AB}}{dt} \cdot \frac{FTA}{|FTA|} - \frac{dV_{AA}}{dt} \cdot \frac{FTB}{|FTB|}$$

Thus the mean value of TACHO is proportional to the rotation speed and its polarity indicates the direction of rotation.

The above function is performed by amplifying the input signals in A_1 and A_2 to obtain V_{AA} and V_{AB} (typ. 7 V_p). From V_{AA} and V_{AB} the external differentiator RC networks R_5C_6 and R_4C_4 give the signals V_{MA} and V_{MB} which are fed to the multipliers.

The second input to each multiplier consists of the sign of the first input of the other multiplier before differentiation, these are obtained using the comparators C_{s1} and C_{s2} . The multiplier outputs, C_{SA} and C_{SB} , are summed by A_3 to give the final output signal TACHO. The peak-to-peak ripple signal of the TACHO can be found from the following expression:

$$V_{\text{ripple p-p}} = \frac{\pi}{4} (\sqrt{2} - 1) \cdot V_{\text{thaco DC}}$$

The max value of TACHO is:

$$V_{\text{tacho max}} = \frac{\pi}{4} \sqrt{2} \cdot V_{\text{thaco DC}}$$

Using the comparators C_1 and C_2 another two signals from V_{AA} and V_{AB} are derived - the logic signals STA and STB.

This signals are used by the microprocessor to determine the position by counting the pulses. The L2910 internal reference voltage is also derived from V_{AA} and V_{AB} :

$$V_{\text{ref}} = |V_{AA}| + |V_{AB}|$$

This reference is used by the D/A converter in the L291 to compensate for variations in input levels, temperature changes and ageing.

The "one pulse per rotation" opto encoder output is connected to pin 12 of the L290 (FTF) where it is squared to give the STF logic output for the microprocessor.

The TACHO signal and V_{ref} are sent to the L291 via filter networks $R_8 C_8 R_9$ and $R_6 C_7 R_7$ respectively. Pin 12 of this chip is the main summing point of the system where TACHO and the D/A converter output are compared.

The input to D/A converter consists of 5 bit word plus a sign bit supplied by the microprocessor. The sign bit represents the direction of motor rotation. The (analogue) output of the D/A converter - DAC/OUT - is compared with the TACHO signal and the resulting error signal is amplified by the error amplifier, and subsequently appears on pin 1.

The ERRV signal (from pin 1, L291) is fed to pin 6 of the final chip, the L292 H-bridge motor-driver. This input signals is bidirectional so it must be converted to a positive signal because the L292 uses a single supply voltage. This is accomplished by the first stage - the level shifter, which uses an internally generated 8 V reference.

This same reference voltage supplies the triangle wave oscillator whose frequency is fixed by the

external RC network (R_{20} , C_{17} - pins 11 and 10) where:

$$f_{\text{osc}} = \frac{1}{2RC} \quad (\text{with } R \geq 8.2 \text{ K}\Omega)$$

The oscillator determines the switching frequency of the output stage and should be in the range 1 to 30 KHz.

Motor current is regulated by an internal loop in the L292 which is performed by the resistors R_{18} , R_{19} and the differential current sense amplifier, the output of which is filtered by an external RC network and fed back to the error amplifier.

The choice of the external components in these RC network (pins 5, 7, 9) is determined by the motor type and the bandwidth requirements. The values shown in the diagram are for a 5 Ω , 5 MH motor. (See L292 Transfer Function Calculation in Application Information).

The error signal obtained by the addition of the input and the current feedback signals (pin 7) is used to pulse width modulate the oscillator signal by means of the comparator. The pulse width modulated signal controls the duty cycle of the Hbridge to give an output current corresponding to the L292 input signal.

The interval between one side of the bridge switching off and the other switching on, τ , is programmed by C_{17} in conjunction with an internal resistor R_{τ} .

This can be found from:

$$\tau = R_{\tau} \cdot C_{\text{pin 10}} \quad (C_{17} \text{ in the diagram})$$

Since R_{τ} is approximately 1.5 K Ω and the recommended τ to avoid simultaneous conduction is 2.5 μs $C_{\text{pin 10}}$ should be around 1.5 nF.

The current sense resistors R_{18} and R_{19} should be high precision types (maximum tolerance $\pm 2\%$) and the recommended value is given by:

$$R_{\text{max}} \cdot I_{\text{o max}} \leq 0.44 \text{ V}$$

It is possible to synchronize two L292's, if desired, using the network shown in fig. 2.

Finally, two enable inputs are provided on the L292 (pins 12 and 13-active low and high respectively).

Thus the output stage may be inhibited by taking pin 12 high or by taking pin 13 low. The output will also be inhibited if the supply voltage falls below 18 V.

The enable inputs were implemented in this way because they are intended to be driven directly by a microprocessor. Currently available microprocessors may generate spikes as high as 1.5 V during

power-up. These inputs may be used for a variety of applications such as motor inhibit during reset of the logical system and power-on reset (see fig. 3).

Figure 2.

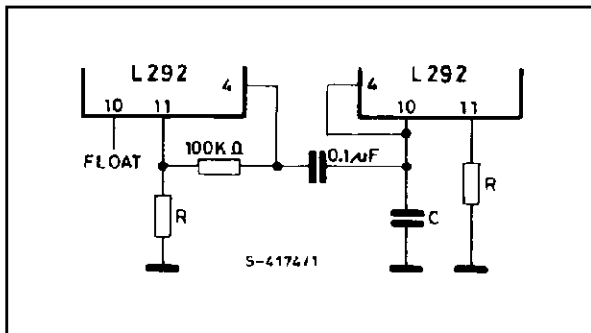

Figure 3.

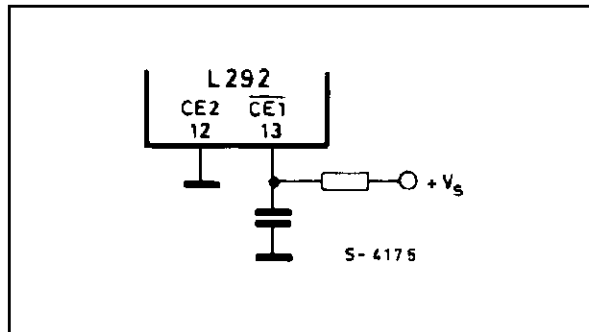
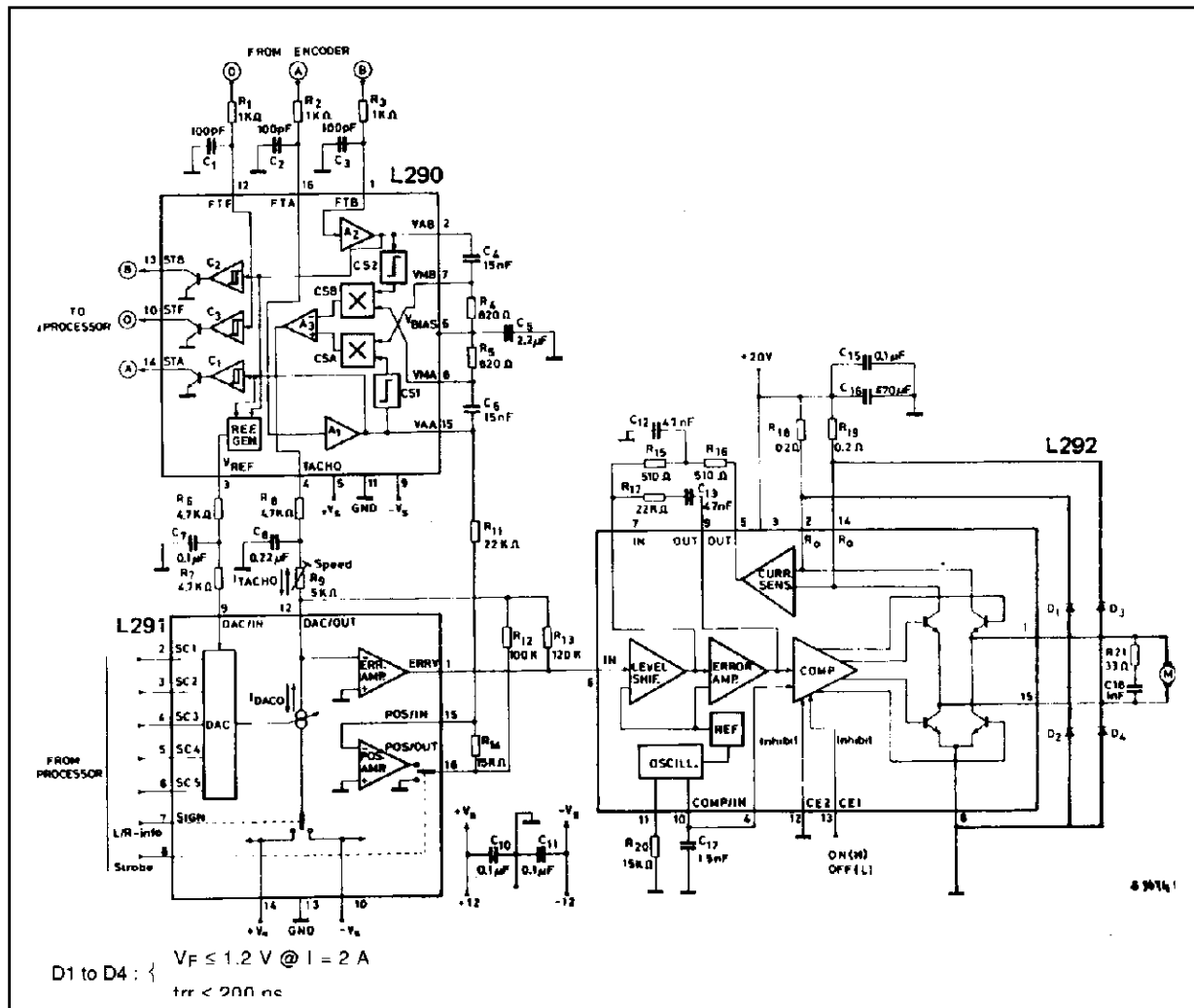

Figure 4 . Application Circuit.



APPLICATION INFORMATION

This section has been added in order to help the designer for the best choice of the values of external components.

Figure 5. L292 Block Diagram.

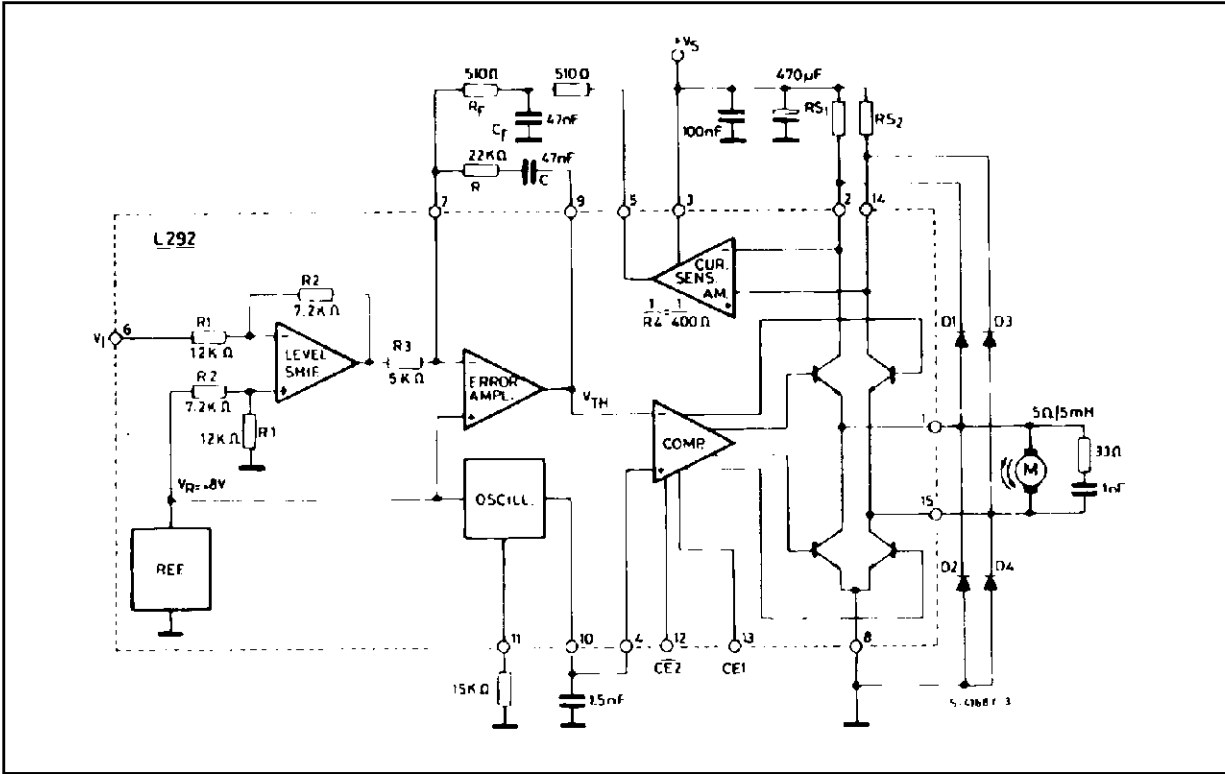

The schematic diagram used for the Laplace analysis of the system is shown in fig. 6.

Figure 6.

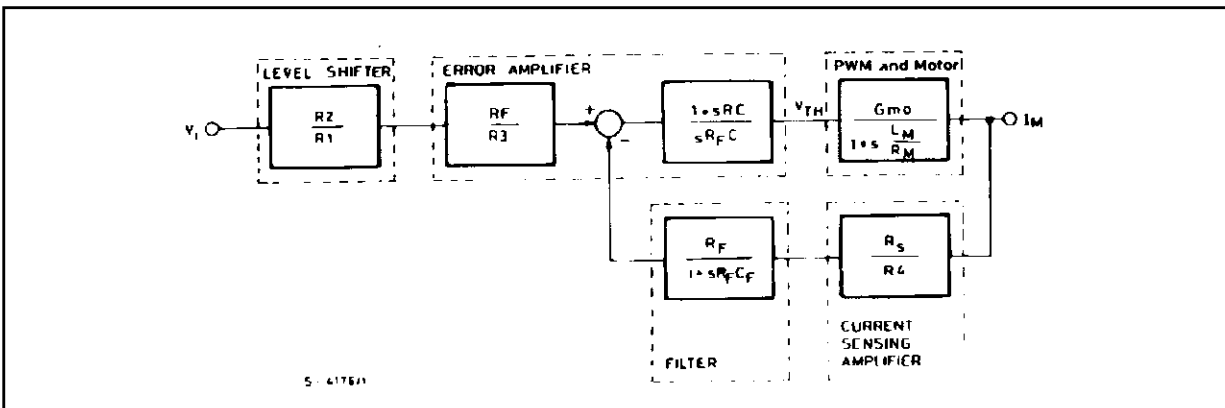

$$R_{S1} = R_{S2} = R_s \text{ (sensing resistors)}$$

$$\frac{1}{R_4} = 2.5 \cdot 10^{-3} \text{ } \Omega \text{ (current sensing amplifier transconductance)}$$

L_M = Motor inductance, R_M = Motor resistance, I_M = Motor current

$$G_{mo} = \frac{I_M}{V_{TH}} \Big|_{s=0} \text{ (DC transfer function from the input of the comparator (} V_{TH} \text{) to the motor current (} I_M \text{)).}$$

Neglecting the V_{CEsat} of the bridge transistors and the V_{BE} of the diodes:

$$G_{mo} = \frac{1}{R_M} \frac{2 V_S}{V_R} \quad \text{where} \quad \begin{array}{l} V_S = \text{supply voltage} \\ V_R = 8 \text{ V (reference voltage)} \end{array} \quad (1)$$

DC TRANSFER FUNCTION

In order to be sure that the current loop is stable the following condition is imposed :

$$1 + sRC = 1 + s \frac{L_M}{R_M} \quad (\text{pole cancellation}) \quad (2)$$

$$\text{from which } RC = \frac{L_M}{R_M} \quad (\text{Note that in practice } R \text{ must be greater than } 5.6 \text{ K}\Omega)$$

The transfer function is then,

$$\frac{I_M}{V_I}(s) = \frac{R_2 R_4}{R_1 R_3} G_{mo} \frac{1 + s R_F C_F}{G_{mo} R_s + s R_4 C + s^2 R_F C_F R_4 C} \quad (3)$$

In DC condition, this is reduced to

$$\frac{I_M}{V_I}(0) = \frac{R_2 R_4}{R_1 R_3} \cdot \frac{1}{R_s} = \frac{0.044}{R_s} \left[\frac{A}{V} \right] \quad (4)$$

OPEN-LOOP GAIN AND STABILITY CRITERION

For $RC = L_M / R_M$, the open loop gain is:

$$A\beta = \frac{1}{s R_{sub} F C} \cdot G_{mo} \frac{R_s}{R_4} \frac{R_F}{1 + s R_F C_F} = \frac{G_{mo} R_s}{R_4} C \frac{1}{s (1 + s R_F C_F)} \quad (5)$$

In order to achieve good stability, the phase margin must be greater than 45° when $|A\beta| = 1$.

That means that, at $f_F = \frac{1}{2 \pi R_F C_F}$ must be $|A\beta| < 1$ (see fig. 7), that is :

$$|A\beta|_f = \frac{1}{2 \pi R_F C_F} = \frac{G_{mo} R_s}{R_4 C} \frac{R_F C_F}{\sqrt{2}} < 1 \quad (6)$$

Figure 7. Open Loop Frequency Response

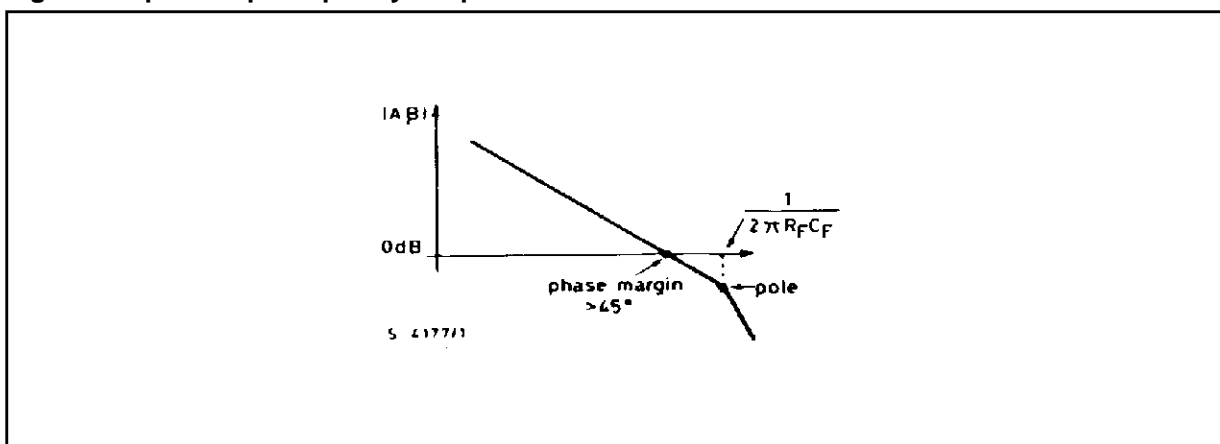

CLOSED-LOOP SYSTEM STEP RESPONSE

a) Small - signals analysis.

The transfer function (3) can be written as follows:

$$\frac{I_M}{V_i}(s) = \frac{0.044}{R_s} \frac{1 + \frac{s}{2\xi\omega_0}}{1 + \frac{2\xi s + s^2}{\omega_0^2}} \quad (7)$$

where $\omega_0 = \frac{\sqrt{G_{m0} R_s}}{R_4 C R_F C_F}$ is the cutoff frequency

$\xi = \frac{\sqrt{R_4 C}}{4 R_F C_F G_{m0} R_s}$ is the dumping factor

By choosing the ξ value, it is possible to determine the system response to an input step signal.

Examples :

1) $\xi = 1$ from which

$$I_M(t) = \frac{0.044}{R_s} \left[1 - e^{-\frac{t}{2R_F C_F}} \left(1 + \frac{t}{4 R_F C_F} \right) \right] \cdot V_i$$

(where V_i is the amplitude of the input step).

2) $\xi = \frac{1}{\sqrt{2}}$ from which

$$I_M(t) = \frac{0.044}{R_s} \left(1 - \cos \frac{t}{2 R_F C_F} e^{-\frac{t}{2 R_F C_F}} \right) V_i$$

Figure 8. Small Signal Step Response (normalized amplitude vs. $t/R_F C_F$).

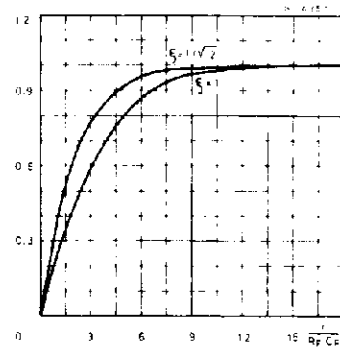

$V_7 = 200$ mV/div.
 $I_M = 100$ mA/div.
 $t = 100$ μ s/div.
 with $V_i = 1.5$ Vp.

It is possible to verify that the L292 works in "closed-loop" conditions during the entire motor current rise-time: the voltage at pin 7 (inverting input of the error amplifier) is locked to the reference voltage V_R , present at the non-inverting input of the same amplifier.

The previous linear analysis is correct for this example.

Decreasing the ξ value, the rise-time of the current decreases. But for a good stability, from relationship (6), the maximum value of ξ is:

$$\xi_{\min} = \frac{1}{2\sqrt[4]{2}} \quad (\text{phase margin} = 45^\circ)$$

b) Large signal response

The large step signal response is limited by slew-rate and inductive load.

In this case, during the rise-time of the motor current, The L292 works in open-loop condition.

CLOSED LOOP SYSTEM BANDWIDTH.

A good choice for x is the value $1/\sqrt{2}$. In this case :

$$\frac{I_M}{V_I}(s) = \frac{0.044}{R_s} \frac{1 + s R_F C_F}{1 + 2s R_F C_F + 2s^2 R_F^2 C_F^2} \quad (8)$$

The module of the transfer function is :

$$\left| \frac{I_M}{V_I} \right| = \frac{0.044}{R_s} \frac{2 \sqrt{1 + \omega^2 R_F^2 C_F^2}}{\sqrt{[(1 + 2\omega R_F C_F)^2 + 1] \cdot [(1 - 2\omega R_F C_F)^2 + 1]}} \quad (9)$$

The cutoff frequency is derived by the expression (9) by putting $\left| \frac{I_M}{V_I} \right| = 0.707 \cdot \frac{0.044}{R_s}$ (-3 dB), from which :

$$\omega_T = \frac{0.9}{R_F C_F} \quad f_T = \frac{0.9}{2\pi R_F C_F}$$

Example :

a) Data

- Motors characteristics:
 - LM = 5 mH
 - RM = 5 W
 - LM / RM = 1msec
- Voltage and current characteristics:
 - Vs = 20 V
 - IM = 2 A
 - VI = 9.1 V
- Closed loop bandwidth : 3 kHz

b) Calculation

- From relationship (4) :

$$R_s = \frac{0.044}{I_M} V_I = 0.2 \Omega$$

and from (1) :

$$G_{mo} = \frac{2V_s}{R_M V_R} = 1 \Omega^{-1}$$

- RC = 1 msec [from expression (2)].
- Assuming $\xi = 1/\sqrt{2}$; from (7) follows :

$$\xi^2 = \frac{1}{2} = \frac{400 C}{4R_F C_F \cdot 0.2}$$

- The cutoff frequency is :

$$f_T = \frac{143 \cdot 10^{-3}}{R_F C_F} = 3 \text{ kHz}$$

c) Summarising

- RC = 1.10⁻³ sec
 - $\frac{1000 C}{R_F C_F} = 1$
 - R_F C_F ≅ 47 μs
- | | |
|---|---|
| } | C = 47 nF |
| } | R = 22 KΩ |
| } | For R _F = 510 Ω → C _F = 92 nF |

MULTIWATT15 PACKAGE MECHANICAL DATA

DIM.	mm			inch		
	MIN.	TYP.	MAX.	MIN.	TYP.	MAX.
A			5			0.197
B			2.65			0.104
C			1.6			0.063
D		1			0.039	
E	0.49		0.55	0.019		0.022
F	0.66		0.75	0.026		0.030
G	1.02	1.27	1.52	0.040	0.050	0.060
G1	17.53	17.78	18.03	0.690	0.700	0.710
H1	19.6			0.772		
H2			20.2			0.795
L	21.9	22.2	22.5	0.862	0.874	0.886
L1	21.7	22.1	22.5	0.854	0.870	0.886
L2	17.65		18.1	0.695		0.713
L3	17.25	17.5	17.75	0.679	0.689	0.699
L4	10.3	10.7	10.9	0.406	0.421	0.429
L7	2.65		2.9	0.104		0.114
M	4.25	4.55	4.85	0.167	0.179	0.191
M1	4.63	5.08	5.53	0.182	0.200	0.218
S	1.9		2.6	0.075		0.102
S1	1.9		2.6	0.075		0.102
Dia1	3.65		3.85	0.144		0.152

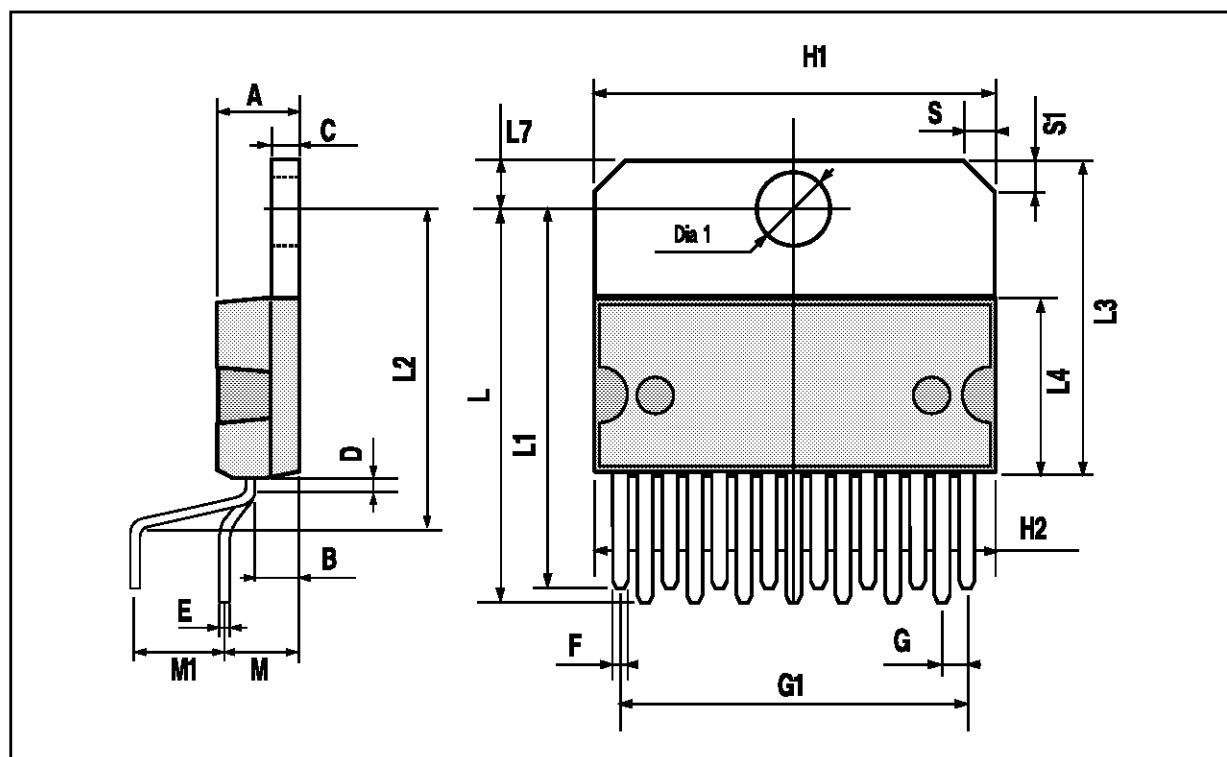

Information furnished is believed to be accurate and reliable. However, SGS-THOMSON Microelectronics assumes no responsibility for the consequences of use of such information nor for any infringement of patents or other rights of third parties which may result from its use. No license is granted by implication or otherwise under any patent or patent rights of SGS-THOMSON Microelectronics. Specifications mentioned in this publication are subject to change without notice. This publication supersedes and replaces all information previously supplied. SGS-THOMSON Microelectronics products are not authorized for use as critical components in life support devices or systems without express written approval of SGS-THOMSON Microelectronics.

© 1994 SGS-THOMSON Microelectronics - All Rights Reserved

SGS-THOMSON Microelectronics GROUP OF COMPANIES

Australia - Brazil - France - Germany - Hong Kong - Italy - Japan - Korea - Malaysia - Malta - Morocco - The Netherlands - Singapore - Spain - Sweden - Switzerland - Taiwan - Thailand - United Kingdom - U.S.A.